

- NOTES**
1. FOR GENERAL DESIGN AND CONSTRUCTION NOTES REFER TO MBRC-2103.
  2. WSUD KERB SHOWN IS ONLY SUITABLE FOR STREET TREE PITS AND SMALL RAINGARDENS. LARGER SYSTEMS MAY NEED SPECIFIC INLET DESIGN OR MULTIPLE INLETS.
  3. WHERE NO PARKING LANE EXISTS, RHS KERB INLET MAY BE REPLACED BY AN OPEN KERB CUT.
  4. WHERE TREE PIT LIES IN A LOW POINT (SAG) RHS INLETS MAY BE ALIGNED AT RIGHT ANGLES TO KERB. ENSURE DRAINAGE IS INSTALLED APPROPRIATELY TO MANAGE STORMWATER VOLUMES.
  5. ENSURE TREE PIT DRAINAGE IS CONNECTED TO STORMWATER SYSTEM TO AVOID FLOODING THE TREE.
  6. TREE PITS ARE TO BE LOCATED UPSTREAM OF GULLY PITS.
  7. DRAWING DETAIL BASED ON THE BRISBANE CITY COUNCIL DRAWING UMS-164, JUNE 2010.
  8. ALL DIMENSIONS IN MILLIMETRES UNLESS SPECIFIED OTHERWISE.

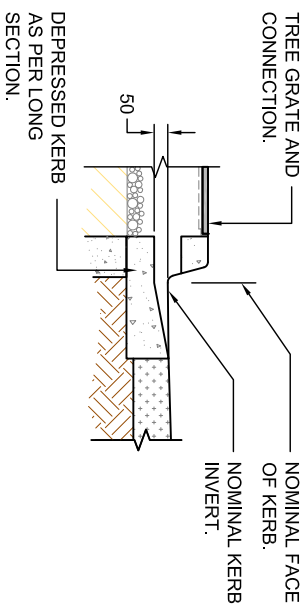
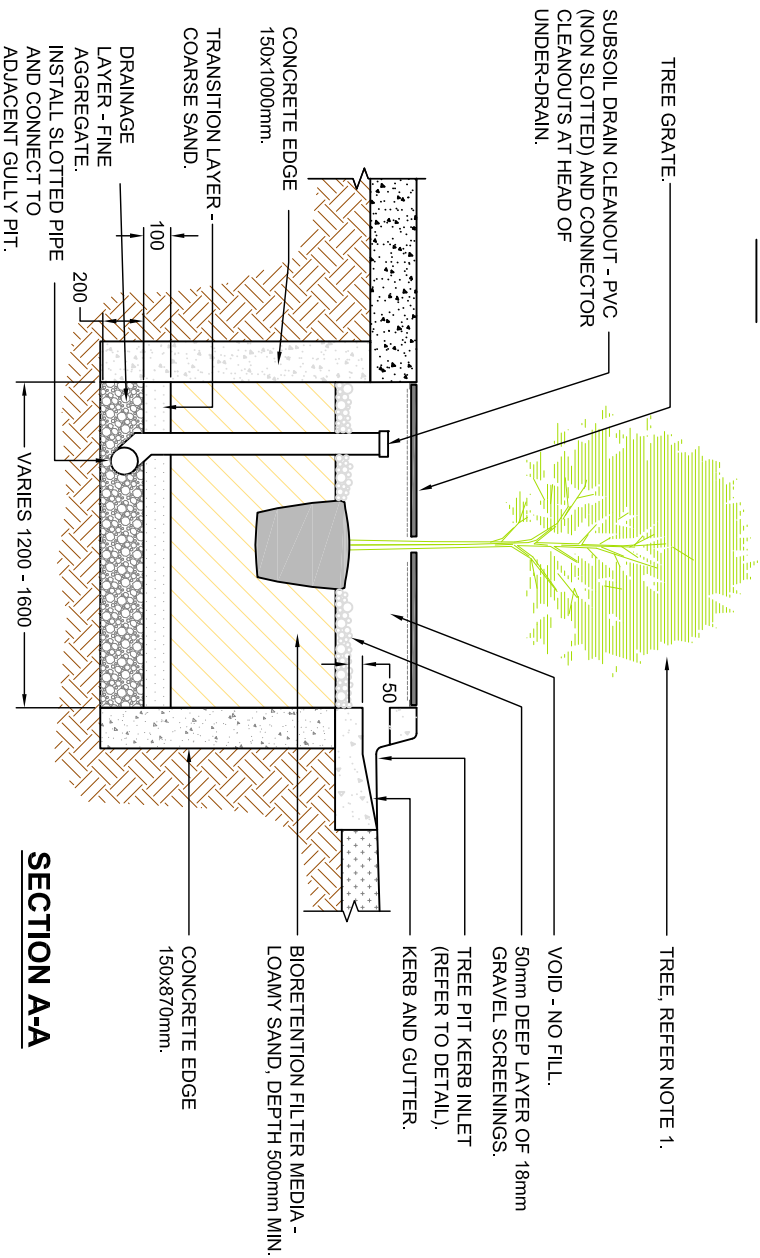

**TREE PIT KERB INLET TYPICAL SECTION**

**TREE PIT KERB INLET ELEVATION**

|  |             |             |
|--|-------------|-------------|
| VERSION  | DATE        | COMMENTS    |
| A  | 25 FEB 13   | FIRST ISSUE |
|   |             |             |
| DRAWING TITLE  |             |             |
| BIORETENTION TREE PIT  |             |             |
| DRAWING No:  | MBRC - 2101 | VERSION:    |
|  |             | A           |

- NOTES**
- FOR GENERAL DESIGN AND CONSTRUCTION NOTES REFER TO MBRC-2103.
  - A ROOT BARRIER SHOULD BE INSTALLED ON THE ALLOTMENT SIDE OF THE BIORETENTION SYSTEM WHERE CONDUITS FOR SERVICES (E.G. SEWERAGE, WATER) ARE WITHIN 1000mm OF THE FILTER MEDIA.
  - ALL DIMENSIONS IN MILLIMETRES UNLESS SPECIFIED OTHERWISE.

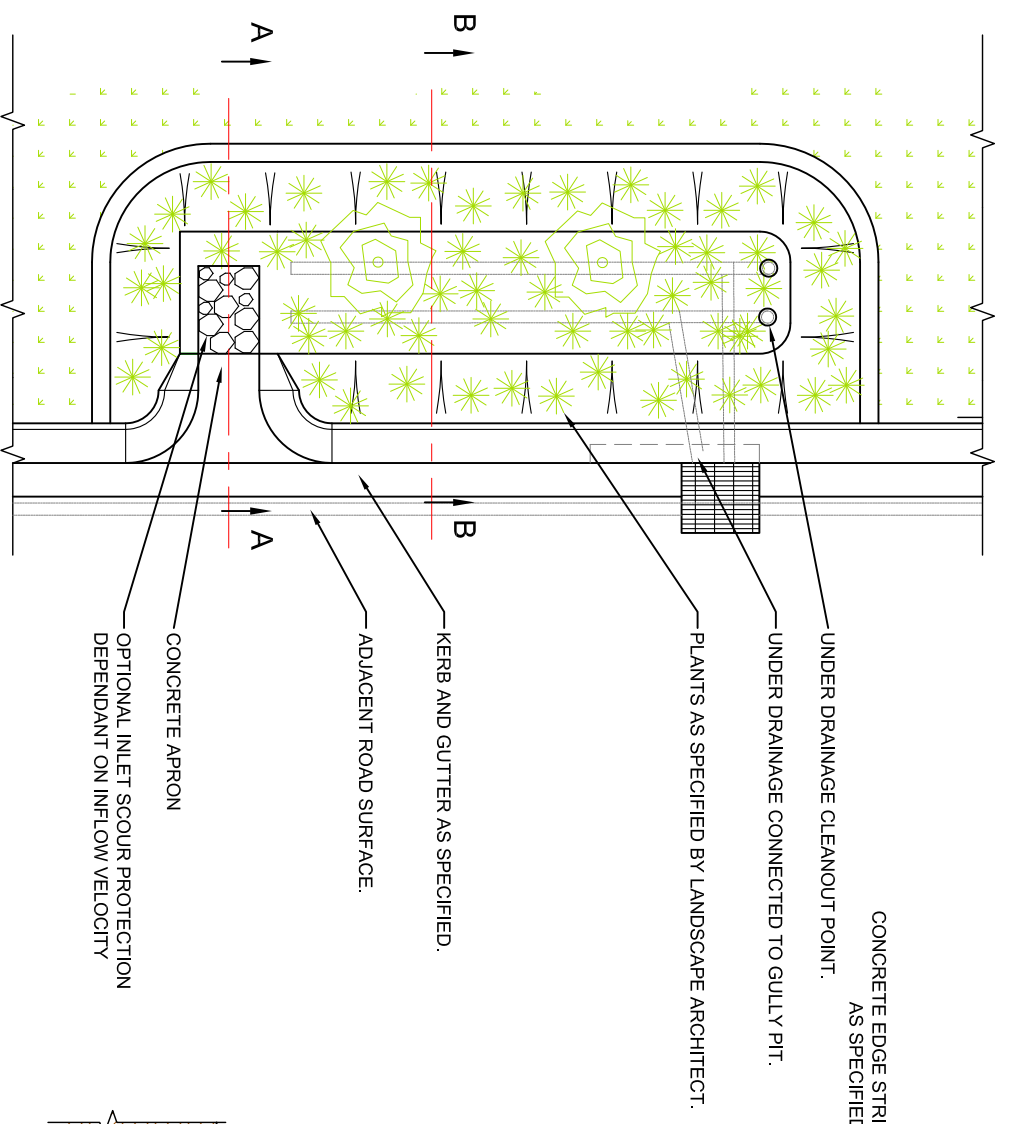

CONCRETE EDGE STRIP AS SPECIFIED.

UNDER DRAINAGE CLEANOUT POINT.

UNDER DRAINAGE CONNECTED TO GULLY PIT.

PLANTS AS SPECIFIED BY LANDSCAPE ARCHITECT.

KERB AND GUTTER AS SPECIFIED.

ADJACENT ROAD SURFACE.

CONCRETE APRON

OPTIONAL INLET SCOUR PROTECTION DEPENDANT ON INFLOW VELOCITY

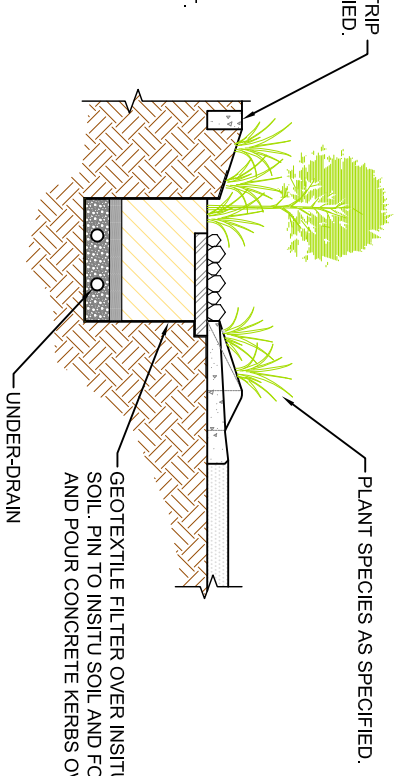

PLANT SPECIES AS SPECIFIED.

GEOTEXTILE FILTER OVER INSITU SOIL. PIN TO INSITU SOIL AND FORM AND POUR CONCRETE KERBS OVER.

UNDER-DRAIN

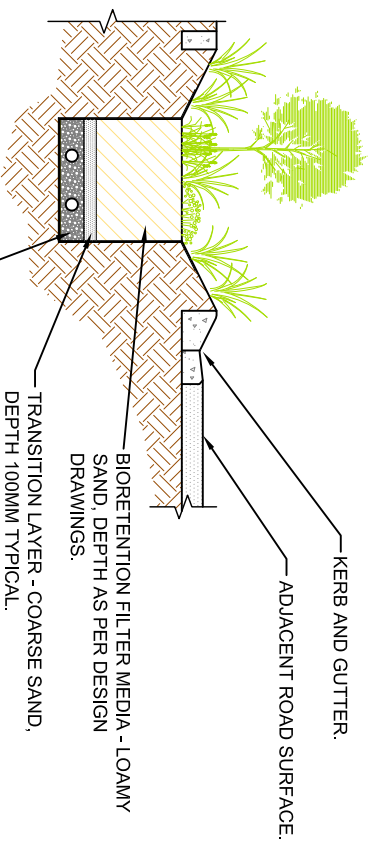

KERB AND GUTTER.

ADJACENT ROAD SURFACE.

BIORETENTION FILTER MEDIA - LOAMY SAND, DEPTH AS PER DESIGN DRAWINGS.

TRANSITION LAYER - COARSE SAND, DEPTH 100MM TYPICAL.

DRAINAGE LAYER - FINE AGGREGATE, DEPTH 200MM TYPICAL.

**SECTION B-B**

|  |             |             |
|--|-------------|-------------|
| VERSION  | DATE        | COMMENTS    |
| A  | 25 FEB 13   | FIRST ISSUE |
|  |             |             |
| DRAWING TITLE  |             |             |
| STREETSCAPE BIORETENTION   |             |             |
| DRAWING No:  | MBRC - 2102 | VERSION:    |
|  |             | A           |
|   |             |             |

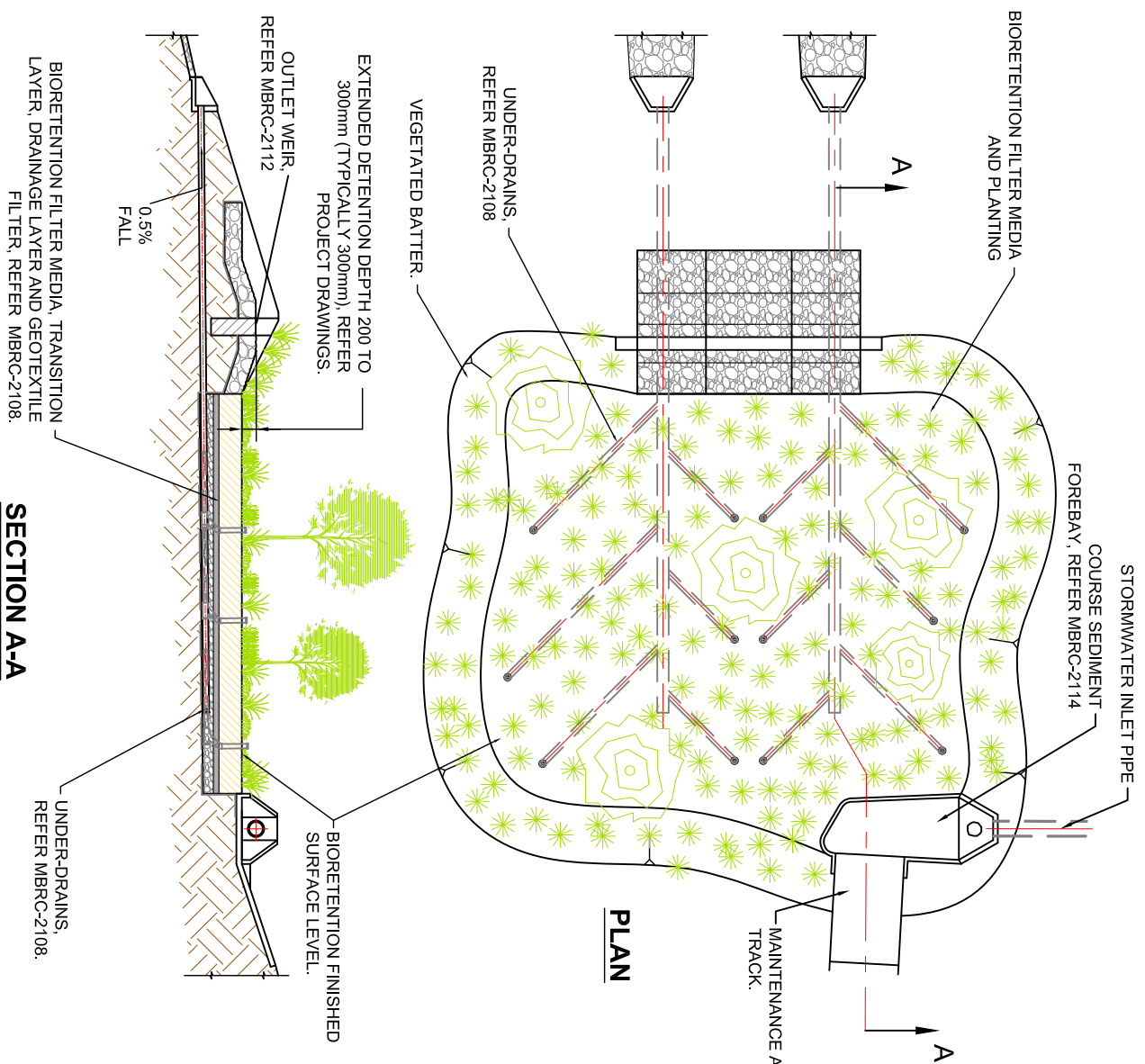

## NOTES

- GENERAL DESIGN** TO BE IN ACCORDANCE WITH 'WATER SENSITIVE URBAN DESIGN TECHNICAL GUIDELINES' (WATER BY DESIGN).
- CONSTRUCTION** TO BE IN ACCORDANCE WITH 'CONSTRUCTION AND ESTABLISHMENT GUIDELINES: SWALES, BIORETENTION SYSTEMS AND WETLANDS' (WATER BY DESIGN).
- CONSTRUCTION TOLERANCES** AS DOCUMENTED IN CONSTRUCTION AND ESTABLISHMENT GUIDELINES: SWALES, BIORETENTION SYSTEMS AND WETLANDS' (WATER BY DESIGN). CONSTRUCTION TOLERANCES MUST BE NOTED ON PROJECT PLANS. INVERT LEVELS AND BASE LEVELS MUST BE NOTED ON PROJECT DRAWINGS.
- FILTER CLOTH** - PROPRIETARY PRODUCT, BIDUM A24 OR EQUIVALENT, NON-WOVEN GEOTEXTILE. FILTER CLOTH NOT TO BE PLACED BETWEEN ANY FILTER LAYERS. IMPERVIOUS LINER MAY BE REQUIRED SUBJECT TO SOIL TESTING REQUIREMENTS IN ACCORDANCE WITH 'WATER SENSITIVE URBAN DESIGN TECHNICAL GUIDELINES' (WATER BY DESIGN).
- BIORETENTION MEDIA** SPECIFICATION SHALL BE IN ACCORDANCE WITH THE 'ADOPTION GUIDELINES FOR STORMWATER BIOFILTRATION SYSTEMS' (FAWB).
- BIORETENTION HYDRAULIC CONDUCTIVITY** SHALL BE IN ACCORDANCE WITH THE 'ADOPTION GUIDELINES FOR STORMWATER BIOFILTRATION SYSTEMS' (FAWB). THE NUMBER OF SAMPLES TO BE TESTED SHALL BE IN ACCORDANCE WITH THE 'WATER SENSITIVE URBAN DESIGN TECHNICAL GUIDELINES' (WATER BY DESIGN)
- UNDER-DRAINS**: SLOTTED RIGID PIPE (UPVC OR SIMILAR TO AS 2439-1) OR APPROVED EQUIVALENT, 0.5% MIN. GRADE. REFER PROJECT DRAWINGS FOR DIAMETER AND INVERT LEVEL (TYPICALLY Ø100-150). PIPE SHOULD NOT BE INSTALLED WITH A FILTER SOCK SURROUNDING PIPE. PIPE JOINS SHOULD BE GLED WITH PLUMBING CEMENT. UNDER-DRAINAGE PIPES SHALL BE SEALED INTO PITS USING GROUTS OR OTHER APPROVED WATERTIGHT SEAL. PIPES TO BE INSTALLED AT NO GREATER THAN 1500MM CENTRES, 50mm DRAINAGE LAYER (FINE AGGREGATE) COVER OVER SLOTTED PIPE. UNDER-DRAIN CLEAN-OUT IN ACCORDANCE WITH 'WATER SENSITIVE URBAN DESIGN TECHNICAL GUIDELINES' (WATER BY DESIGN).
- VEGETATED BATTER SLOPES** (1 IN 2 MAX, 1 IN 4 TYPICAL) AND **BATTER TOPSOIL REQUIREMENTS** REFER TO PROJECT DRAWINGS.
- VEGETATION**: PLANT LAYOUT TO BE AS SPECIFIED ON A PROJECT TO PROJECT BASIS. PLANT SPECIFICATION AND DENSITY SHALL BE IN ACCORDANCE WITH 'WATER SENSITIVE URBAN DESIGN TECHNICAL GUIDELINES' (WATER BY DESIGN).
- BASEIN FINISHED SURFACE LEVEL** IS TOP OF FILTER MEDIA. SURFACE TO BE MULCHED AND PLANTED AS PER LANDSCAPE DRAWINGS.
- SERVICES**: LOCATION OF SERVICES TO BE VERIFIED PRIOR TO EXCAVATION. BIORETENTION SYSTEMS MUST HAVE A MINIMUM HORIZONTAL SETBACK OF 300mm FROM ANY WATER SUPPLY AND SEWERAGE INFRASTRUCTURE.
- ALL DIMENSIONS IN MILLIMETRES UNLESS SPECIFIED OTHERWISE.

|         |           |             |
|---------|-----------|-------------|
| VERSION | A         | FIRST ISSUE |
| DATE    | 25 FEB 13 | COMMENTS    |
|         |           |             |
|         |           |             |
|         |           |             |



BMT WBM



DRAWING TITLE  
BIORETENTION BASIN

DRAWING No: MBRC - 2103

VERSION: A

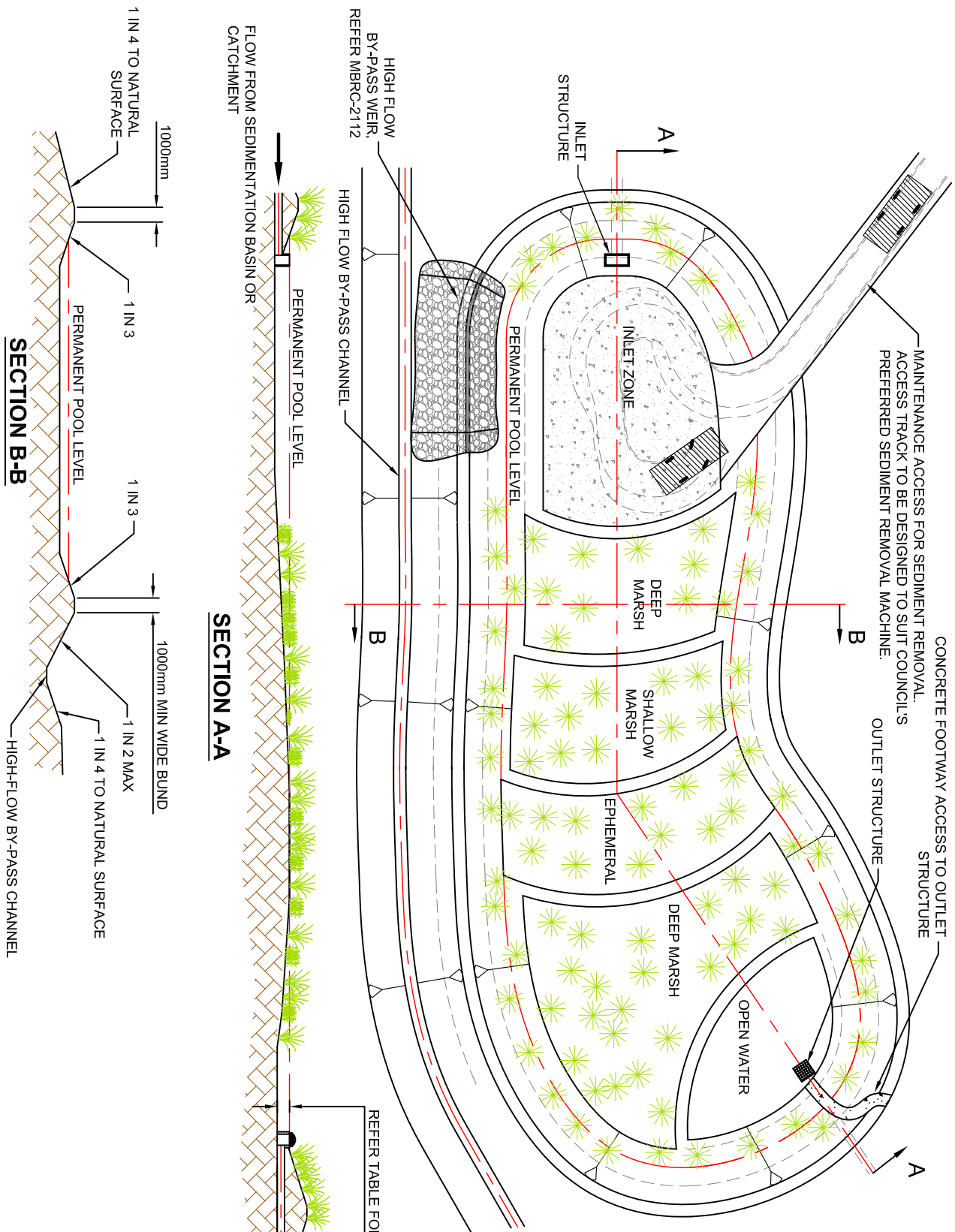

- NOTES**
1. FOR GENERAL DESIGN AND CONSTRUCTION NOTES REFER TO MBRC-2103.
  2. ENGINEERING WORKS TO BE DESIGNED IN ACCORDANCE WITH COUNCIL'S ENGINEERING GUIDELINES
  3. WETLAND INLET ZONE SHALL BE CONSTRUCTED WITH A COMPACTED CLAY BASE TO ASSIST WITH MAINTENANCE. THE BASE MUST HAVE A BEARING CAPACITY TO SUPPORT MAINTENANCE MACHINERY WHEN ACCESS IS REQUIRED INTO THE BASIN.
  4. THE PROVISION FOR A MAINTENANCE DRAIN SHALL BE CONFIRMED WITH COUNCIL.
  5. ALL DIMENSIONS IN MILLIMETRES UNLESS SPECIFIED OTHERWISE.

| ZONE                  | DEPTH* (m)    |
|-----------------------|---------------|
| INLET ZONE/OPEN WATER | 0.5 to 1.5    |
| DEEP MARSH            | 0.35 to 0.5   |
| SHALLOW MARSH         | 0.2 to 0.35   |
| EPHEMERAL             | 0.0 to +0.2** |

\* DEPTH REFERS TO DEPTH BELOW PERMANENT POOL LEVEL.  
 \*\* \* DENOTES LEVEL ABOVE PERMANENT POOL LEVEL.

**SECTION A-A**

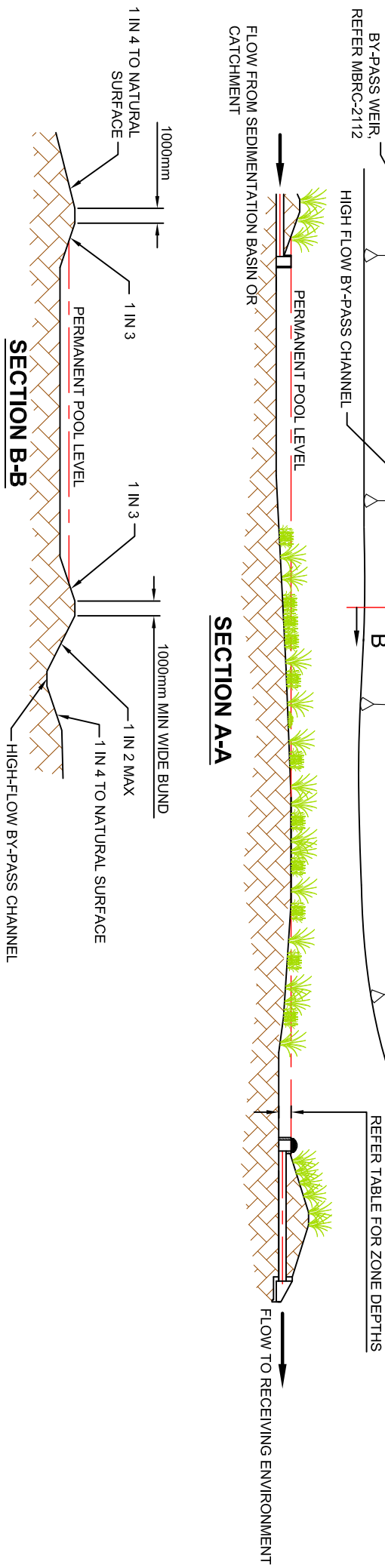

**SECTION B-B**

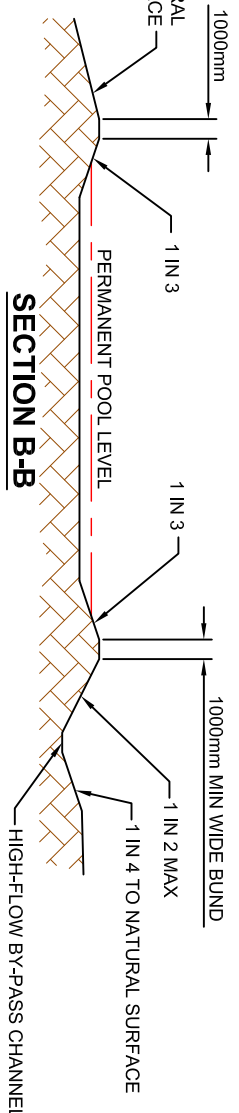

|  |             |          |           |          |             |
|--|-------------|----------|-----------|----------|-------------|
| VERSION  | A           | DATE     | 25 FEB 13 | COMMENTS | FIRST ISSUE |
|   |             |          |           |          |             |
| DRAWING TITLE  |             |          |           |          |             |
| <b>CONSTRUCTED WETLAND<br/>         TYPICAL PLAN AND SECTIONS</b>  |             |          |           |          |             |
| DRAWING No:  | MBRC - 2104 | VERSION: | A         |          |             |



MAINTENANCE ACCESS FOR SEDIMENT REMOVAL.  
ACCESS TRACK TO BE DESIGNED TO SUIT COUNCIL'S  
PREFERRED SEDIMENT REMOVAL MACHINE.

DENSE VEGETATION TO INHIBIT PUBLIC  
ACCESS TO BASIN.  
VEGETATION MAY BE DAMAGED DURING  
(AND NEED REPLANTING/ REHABILITATION)  
FOLLOWING SEDIMENT REMOVAL.

FOOTWAY ACCESS RAMP TO  
OUTLET STRUCTURE  
(MAXIMUM GRADIENT 1 IN 8)

- NOTES**
- FOR GENERAL DESIGN AND CONSTRUCTION NOTES SEE MBRC-2103.
  - ENGINEERING WORKS TO BE DESIGNED IN ACCORDANCE WITH COUNCIL'S ENGINEERING GUIDELINES
  - SEDIMENTATION BASIN SHALL BE CONSTRUCTED WITH A COMPACTED CLAY BASE TO ASSIST WITH MAINTENANCE. THE BASE MUST HAVE A BEARING CAPACITY TO SUPPORT MAINTENANCE MACHINERY WHEN ACCESS IS REQUIRED INTO THE BASIN.
  - DRAINAGE REQUIREMENTS FOR SEDIMENT BASIN TO BE CONFIRMED WITH COUNCIL.
  - ALL DIMENSIONS IN MILLIMETRES UNLESS SPECIFIED OTHERWISE.

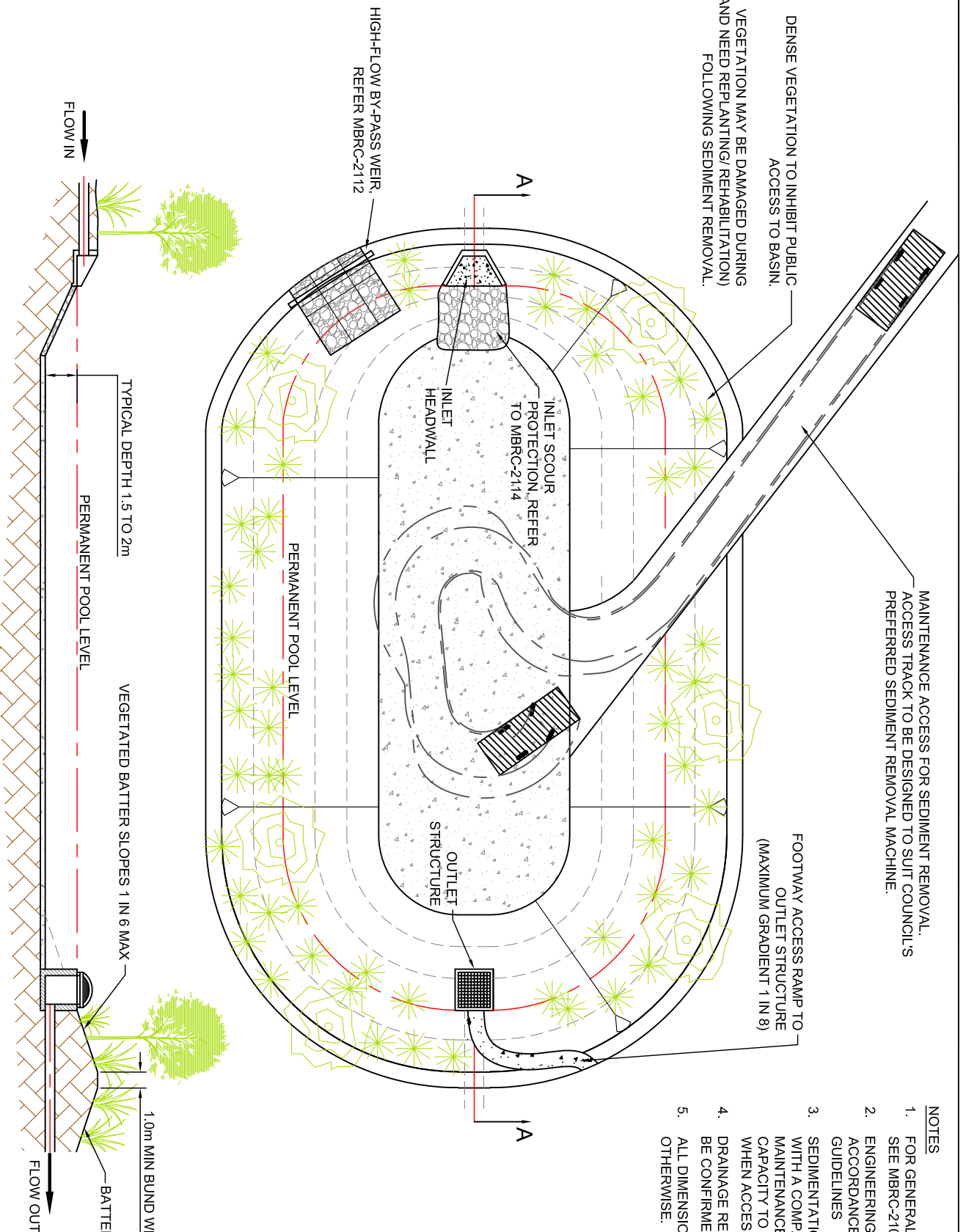

**SECTION A-A**

|         |           |             |
|---------|-----------|-------------|
| VERSION | DATE      | COMMENTS    |
| A       | 25 FEB 13 | FIRST ISSUE |



DRAWING TITLE  
SEDIMENT BASIN  
TYPICAL PLAN AND SECTION

|             |             |          |   |
|-------------|-------------|----------|---|
| DRAWING No: | MBRC - 2105 | VERSION: | A |
|-------------|-------------|----------|---|

PLANTED SWALE. FOR LANDSCAPE PLANTING, CHANNEL DIMENSIONS AND SLOPE, REFER TO NOTE 1.

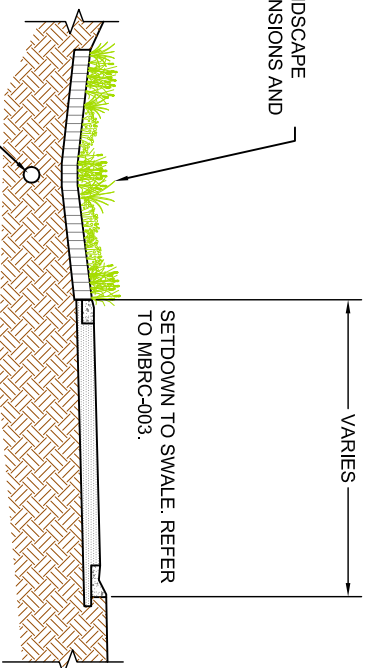

SLOTTED CONVEYANCE PIPE (OPTIONAL) CONNECTED TO STORMWATER DRAINAGE.

### TYPE 1 SWALE

PROVIDE KERB TRANSITIONS AT NO GREATER THAN 15m CRS. IN KERB TO ALLOW WATER INTO SWALE. REFER TO MBRC-2107 FOR KERB TRANSITION DETAIL.

PLANTED SWALE. FOR LANDSCAPE PLANTING, CHANNEL DIMENSIONS AND SLOPE, REFER TO NOTE 1.

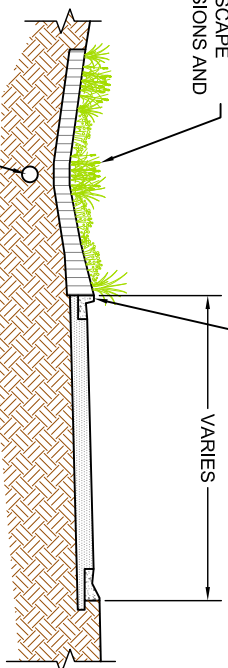

SLOTTED CONVEYANCE PIPE (OPTIONAL) CONNECTED TO STORMWATER DRAINAGE.

### ALTERNATIVE TYPE 1 SWALE

#### NOTES

1. CHANNEL DIMENSIONS: SWALE BATTER SLOPES SHALL NOT BE STEEPER THAN 1V:4H. SWALE IS TO HAVE A MAXIMUM INVERT DEPTH (DEPTH FROM INVERT TO TOP OF BATTER OR KERB EDGE) OF 400mm. SWALE CAN BE TRAPEZOIDAL (IE. WITH A BASE WIDTH) OR V-SHAPED.
2. SWALE LONGITUDINAL GRADIENT: SWALE GRADIENT MUST NOT EXCEED 5% OR BE BELOW 1% ALONG ANY 10m SECTION OF THE SWALE. FOR SECTIONS WITH GRADIENTS LESS THAN 1%, A BIORETENTION SWALE (REFER TO MBRC-007) IS RECOMMENDED.
3. MAXIMUM FLOW/DEPTH: VELOCITY DEPTH PRODUCT FOR Q2 EVENT MUST BE LESS THAN 0.4m<sup>2</sup>/s (WHICH WILL TYPICALLY NECESSITATE THE USE OF FIELD INLETS WITHIN THE SWALE AND CONVEYANCE PIPES). MAXIMUM PIPE OF FLOW IN Q2 EVENT MUST BE LESS THAN 300mm. CONSIDERATION MUST BE GIVEN TO MAJOR (EG. Q100) FLOWS AND ROAD CAPACITY.
4. FIELD INLETS: FIELD INLETS TO BE LOCATED WITHIN SWALE CHANNEL UPSTREAM OF ROAD CROSSINGS AND/OR TO CONVEY FLOWS ABOVE SWALE CAPACITY TO PIPED DRAINAGE. MAXIMUM FIELD INLET SPACINGS TO BE DETERMINED BASED ON NOTE 3 REQUIREMENTS, BUT NOT TO EXCEED 60m. LANDSCAPING (EG. DENSE PLANTING OF SHRUBS) SHOULD BE PROVIDED AROUND FIELD INLETS TO REDUCE ACCESS TO FIELD INLETS BY PUBLIC.
5. ADJACENT LAND USAGE: FOR 'TYPE 1' SWALES, LAND USAGE IMMEDIATELY ADJACENT TO SWALE SHALL BE OPEN SPACE (EG. FOREST, PARK).
6. TRAFFIC CONTROLS: DESIGNERS SHALL INCORPORATE FEATURES THAT PREVENT OR DISCOURAGE THE DRIVING OR PARKING OF VEHICLES IN THE SWALE. BOLLARDS MAY BE USED WITHIN THE TREES AND POLES ALIGNMENT IN ACCORDANCE WITH THE FOLLOWING:
  - MINIMUM HEIGHT TO BE 1000mm
  - BOLLARDS TO BE MADE FROM SUSTAINABLE PRODUCTS
  - PREFERABLE MAXIMUM IN CROSS SECTION TO BE 150 X 150
  - NO CONCRETE FOOTINGS.
  - CONSIDER VISIBILITY WHEN SPECIFYING COLOUR
  - NOT RECOMMENDED FOR GREATER THAN 50km/hr ENVIRONMENTS.
  - REFLECTORS SHOULD BE FITTED.
  - KERBS: KERBS TO BE CONSTRUCTED IN ACCORDANCE WITH MBRC STANDARD DETAILS.
8. FOR CONCRETE EDGE DETAILS, REFER TO MBRC STANDARD DRAWINGS.
9. FOR ROAD WIDTHS, REFER TO MBRC STANDARD DRAWINGS.
10. DRAWING DETAIL BASED ON THE BRISBANE CITY COUNCIL DRAWING UMS 159-1, JUNE 2010.
11. ALL DIMENSIONS IN MILLIMETRES UNLESS SPECIFIED OTHERWISE.

|         |           |             |
|---------|-----------|-------------|
| VERSION | DATE      | COMMENTS    |
| A       | 25 FEB 13 | FIRST ISSUE |
|         |           |             |
|         |           |             |



DRAWING TITLE  
STREETSCAPE SWALE - TYPICAL SECTION  
SHEET 1

DRAWING No: MBRC - 2106      VERSION: A

**NOTES**

1. FOR GENERAL NOTES REFER TO MBRC-2106 AND MBRC-2103
2. ENGINEERING WORKS TO BE DESIGNED IN ACCORDANCE WITH COUNCIL'S ENGINEERING GUIDELINES.
3. DRAWING DETAIL BASED ON THE BRISBANE CITY COUNCIL DRAWING UMS 159-2, JUNE 2010.
4. ALL DIMENSIONS IN MILLIMETRES UNLESS SPECIFIED OTHERWISE.

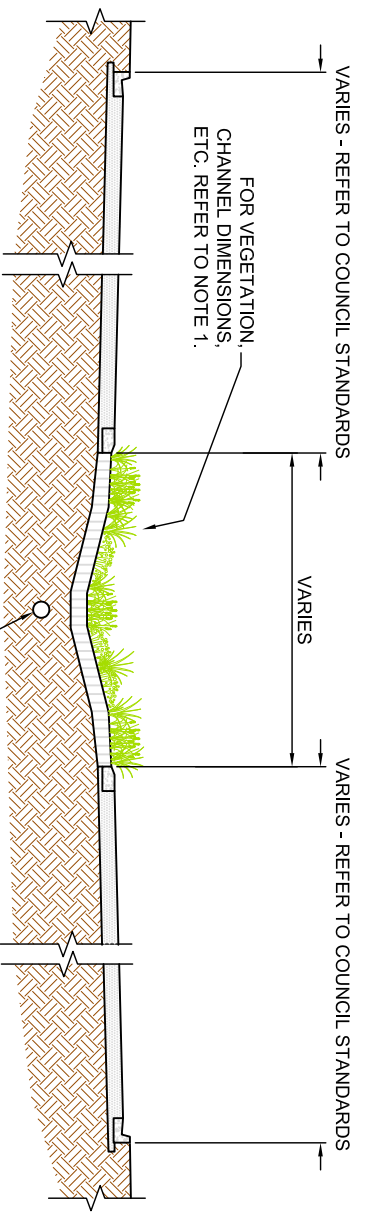
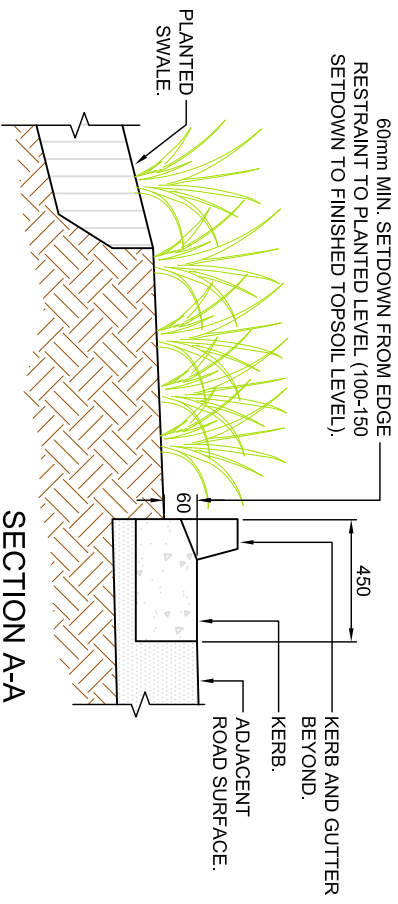
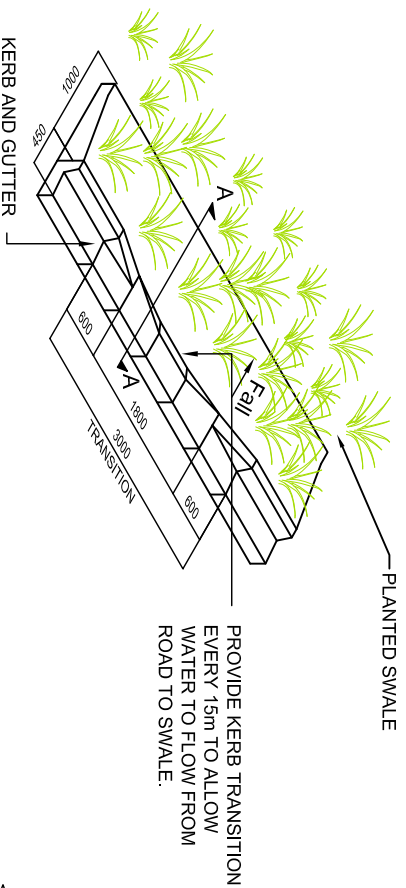

**TYPE 2 SWALE**

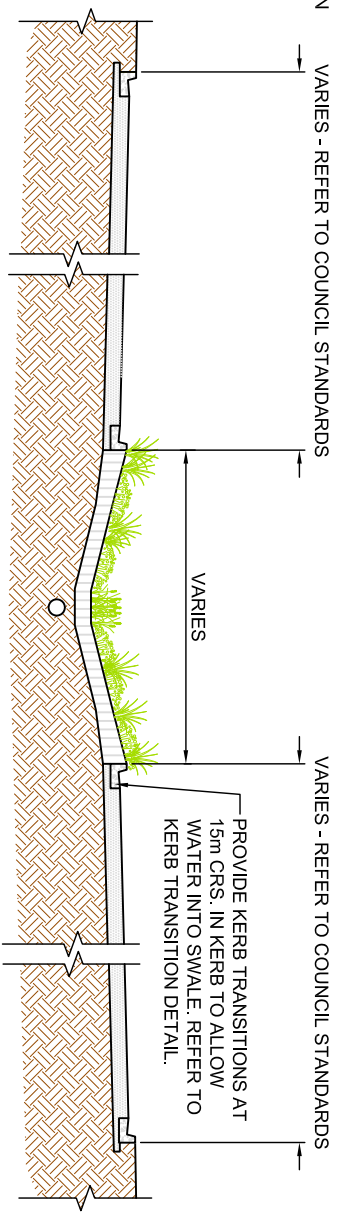

**ALTERNATIVE TYPE 2 SWALE**

|               |             |                                     |   |
|---------------|-------------|-------------------------------------|---|
| DRAWING TITLE |             | STREETSCAPE SWALE - TYPICAL SECTION |   |
| SHEET 2       |             | SHEET 2                             |   |
| VERSION       | DATE        | COMMENTS                            |   |
| A             | 25 FEB 13   | FIRST ISSUE                         |   |
| BMT WBM       |             | Moreton Bay Regional Council        |   |
| DRAWING No:   | MBRC - 2107 | VERSION:                            | A |

EXTENDED DETENTION DEPTH 200 TO 300mm (TYPICALLY 300mm), REFER PROJECT DRAWINGS.

RAISED PIT GRATE, IN ACCORDANCE WITH MBRC STANDARD DRAWINGS.

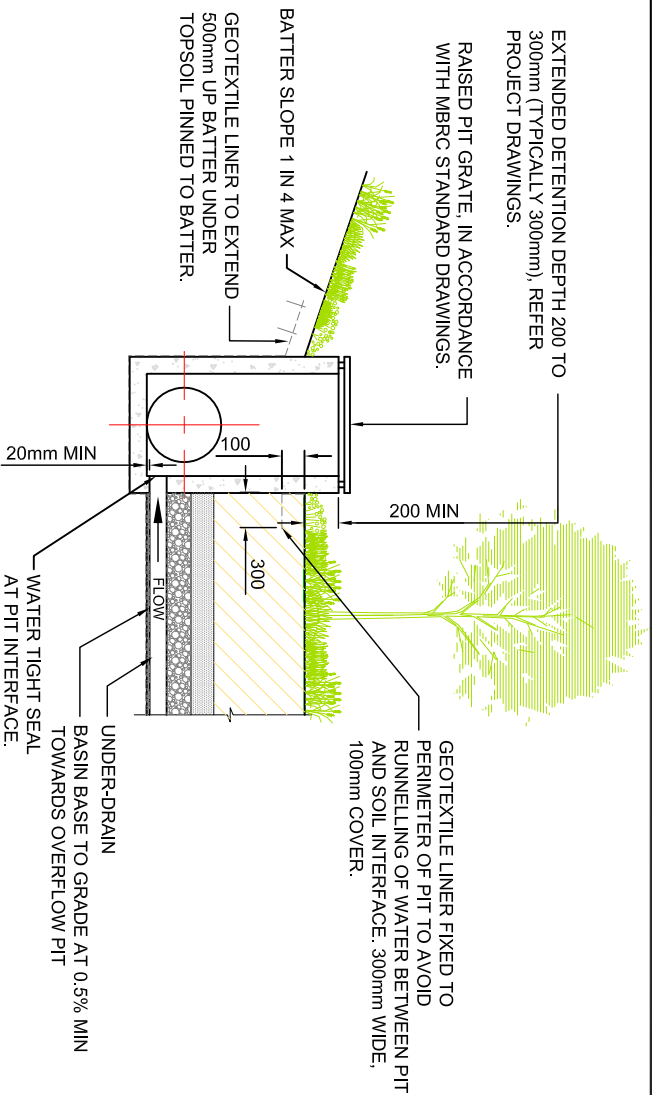

**BIORETENTION OVERFLOW PIT - TYPICAL SECTION**

C.I. CAP. EXTEND CAP TO APPROX. 150mm ABOVE BIORETENTION SWALE SURFACE. PROVIDE LOCKING FUNCTION OR SECURE CAP WITH SCREWS.

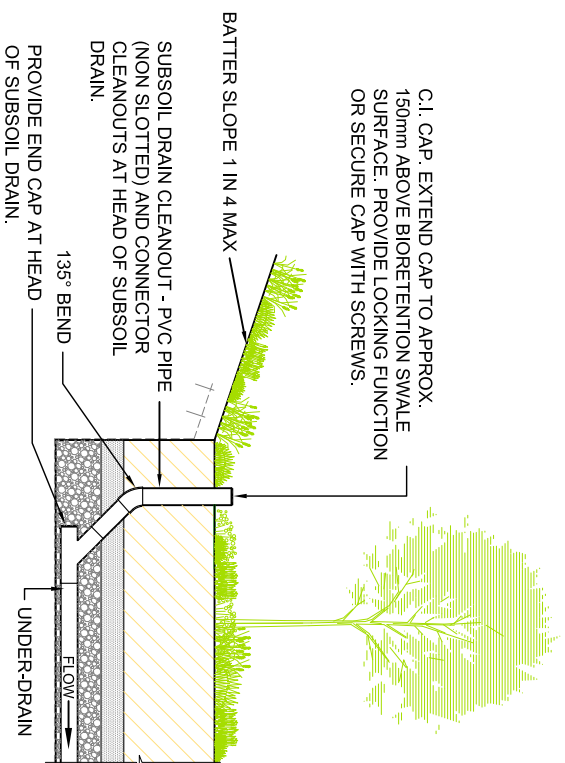

**BIORETENTION UNDER-DRAIN CLEANOUT - TYPICAL SECTION**

**NOTES**

- FOR GENERAL DESIGN AND CONSTRUCTION NOTES REFER TO MBRC-2103.
- TRAFFIC CONTROLS: FOR STREETSCAPE SYSTEMS, DESIGNERS SHALL INCORPORATE FEATURES THAT PREVENT OR DISCOURAGE THE DRIVING OR PARKING OF VEHICLES IN THE BIORETENTION SYSTEM. BOLLARDS MAY BE USED WITHIN THE TREES AND POLES ALIGNMENT IN ACCORDANCE WITH THE FOLLOWING:
  - MINIMUM HEIGHT TO BE 1000mm
  - CONSIDER VISIBILITY WHEN SPECIFYING COLOUR
  - BOLLARDS TO BE MADE FROM SUSTAINABLE PRODUCTS
  - NOT RECOMMENDED FOR GREATER THAN 50km/hr ENVIRONMENTS
  - PREFERABLE MAXIMUM IN CROSS SECTION TO BE 150x150
  - NO CONCRETE FOOTINGS.
- SERVICES: LOCATION OF SERVICES TO BE VERIFIED PRIOR TO EXCAVATION. BIORETENTION SYSTEMS MUST HAVE A MINIMUM HORIZONTAL SETBACK OF 300mm FROM ANY WATER SUPPLY AND SEWERAGE INFRASTRUCTURE.
- DRAWING DETAIL BASED ON THE BRISBANE CITY COUNCIL DRAWING UMS-160, JUNE 2010.
- ALL DIMENSIONS IN MILLIMETRES UNLESS SPECIFIED OTHERWISE.

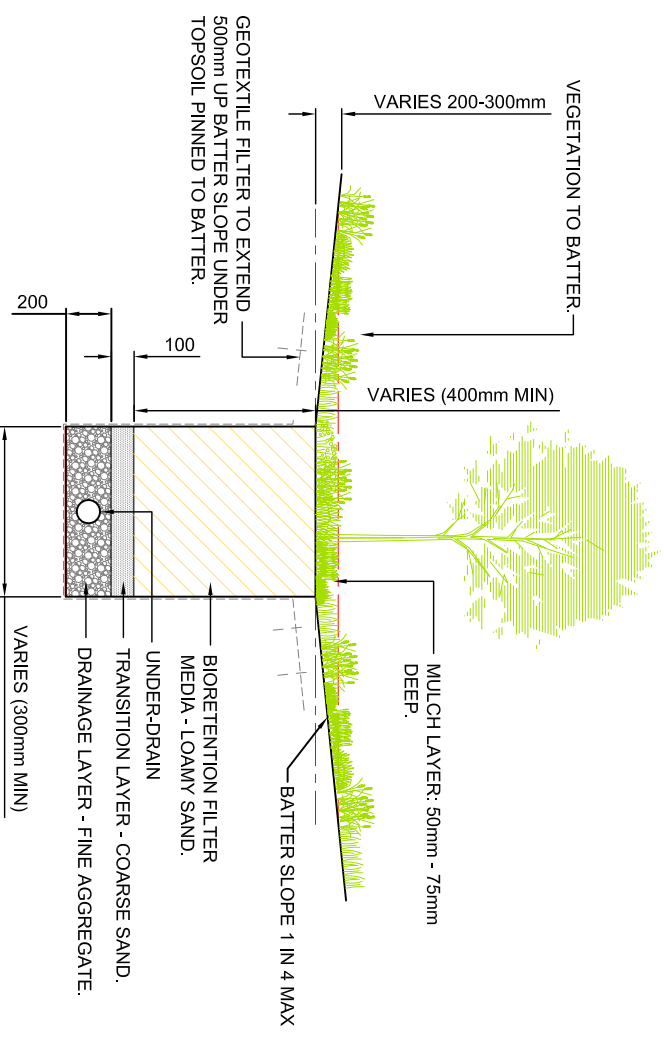

**BIORETENTION SWALE - TYPICAL SECTION**

|         |            |             |
|---------|------------|-------------|
| VERSION | DATE       | COMMENTS    |
| A       | 25 FEB '13 | FIRST ISSUE |



|                                       |             |          |
|---------------------------------------|-------------|----------|
| DRAWING TITLE                         | DRAWING No: | VERSION: |
| BIORETENTION SWALE - TYPICAL SECTIONS | MBRC - 2108 | A        |



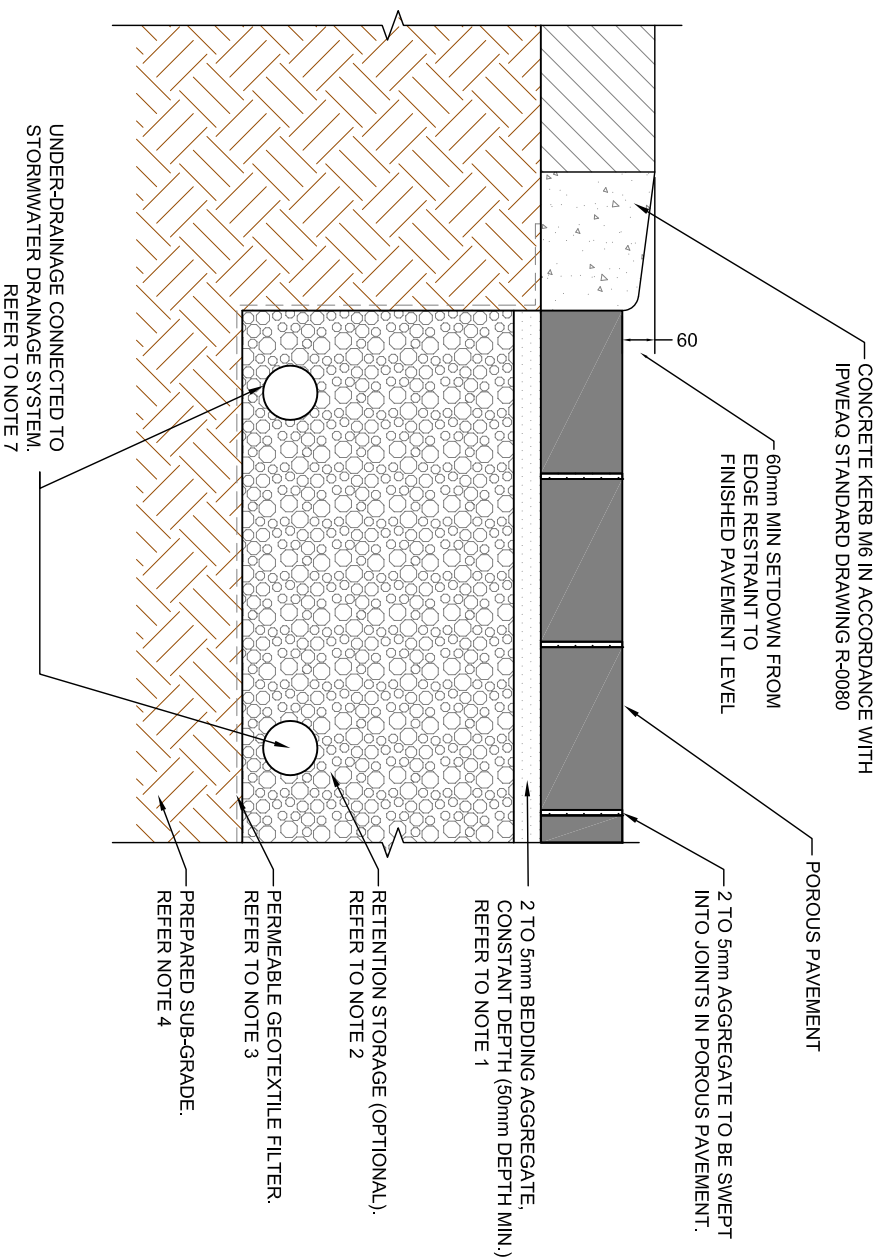

**POROUS PAVEMENT TYPICAL SECTION**

**NOTES**

1. BEDDING AGGREGATE MATERIAL SHALL MEET MATERIAL AND GRADING COMPATIBILITY CRITERIA IN TECHNICAL SPECIFICATION FOR THE WORKS AND/OR THE PAVEMENT MANUFACTURER'S TECHNICAL SPECIFICATIONS.
2. THE RETENTION STORAGE MEDIA SHALL COMPRISE COARSE, SOUND, CLEAN STONE OR ROCK OF GENERALLY UNIFORM PARTICLE SIZE (TYPICALLY 10 TO 63 mm SIZE) AND FREE FROM SILT/CLAY FINES OR OTHER DELETERIOUS MATTER, OR AS SPECIFIED IN THE PAVEMENT MANUFACTURER'S TECHNICAL SPECIFICATION.
3. NON-WOVEN GEOTEXTILE FILTER MEDIA NOT TO BE PLACED BETWEEN ANY FILTER LAYERS. IMPERVIOUS LINER MAY BE REQUIRED SUBJECT TO SOIL TESTING REQUIREMENTS IN ACCORDANCE WITH THE 'WATER SENSITIVE URBAN DESIGN TECHNICAL GUIDELINES' (WATER BY DESIGN).
4. SUB-GRADE TO BE RIPPED/HARROWED PRIOR TO PLACEMENT OF GEOTEXTILE FILTER.
5. WHERE POSSIBLE, ANY RUNOFF DIRECTED TO POROUS PAVEMENTS SHALL BE PRE-TREATED TO REMOVE COARSE TO MEDIUM SEDIMENTS.
6. REFER TO MANUFACTURE'S SPECIFICATION FOR MAXIMUM TRAFFIC LOADING.
7. UNDER-DRAINAGE - SLOTTED PVC PIPE (uPVC OR SIMILAR TO AS2439.1) OR APPROVED EQUIVALENT, 0.5% MINIMUM GRADE, INSTALLED AT 1500mm MAXIMUM CENTRES, DIAMETER TYPICALLY 100-500mm. PIPE JOINS SHOULD BE GLUED WITH PLUMBING CEMENT. UNDER-DRAINAGE PIPE SHALL BE SEALED INTO PITS USING GROUT OR OTHER APPROVED WATER-TIGHT SEAL. 50mm DRAINAGE LAYER (FINE AGGREGATE) COVER OVER SLOTTED PIPE.
8. DRAWING DETAIL BASED ON THE BRISBANE CITY COUNCIL DRAWING UMS-161 JUNE 2010.
9. POROUS PAVEMENT CAN PROVIDE AN ALTERNATIVE TO CONVENTIONAL IMPERMEABLE PAVEMENT IN LOCATIONS SUCH AS COMMERCIAL CAR PARK BAYS, RESIDENTIAL OR LIGHT COMMERCIAL DRIVEWAYS, INDUSTRIAL STORAGE AREAS OR LOADING ZONES, FOOTPATHS, CYCLEWAYS, PARKING PADS (E.G. MAINTENANCE ACCESS) AND TREE PIT SURROUNDS. THE FOLLOWING AREAS, HOWEVER, ARE NOT SUITABLE FOR PERMEABLE PAVING SYSTEMS (ADAPTED FROM GOLD COAST CITY COUNCIL 2007, COOMBS 2003):
  - WHERE A WATER TABLE IS LOCATED WITHIN 2M OF THE PROPOSED PAVEMENT SURFACE
  - AREAS WITH HIGH TRAFFIC VOLUMES OR WITH REGULAR HEAVY VEHICLE TRAFFIC
  - LOCATIONS WITH CLAY SOILS OR SOILS WITH A HYDRAULIC CONDUCTIVITY OF LESS THAN 0.36mm/hr
  - AREAS WHERE IMPERMEABLE ROCK IS LOCATED WITHIN 2m OF THE PROPOSED PAVEMENT SURFACE
  - LOCATIONS SUBJECT TO RUN-OFF WITH A HIGH SEDIMENT LOAD.
10. ALL DIMENSIONS IN MILLIMETRES UNLESS SPECIFIED OTHERWISE.

|         |           |             |
|---------|-----------|-------------|
| VERSION | DATE      | COMMENTS    |
| A       | 25 FEB 13 | FIRST ISSUE |
|         |           |             |
|         |           |             |



|                                   |             |
|-----------------------------------|-------------|
| DRAWING TITLE                     |             |
| POROUS PAVEMENT - TYPICAL SECTION |             |
| DRAWING No:                       | MBRC - 2109 |
| VERSION:                          | A           |



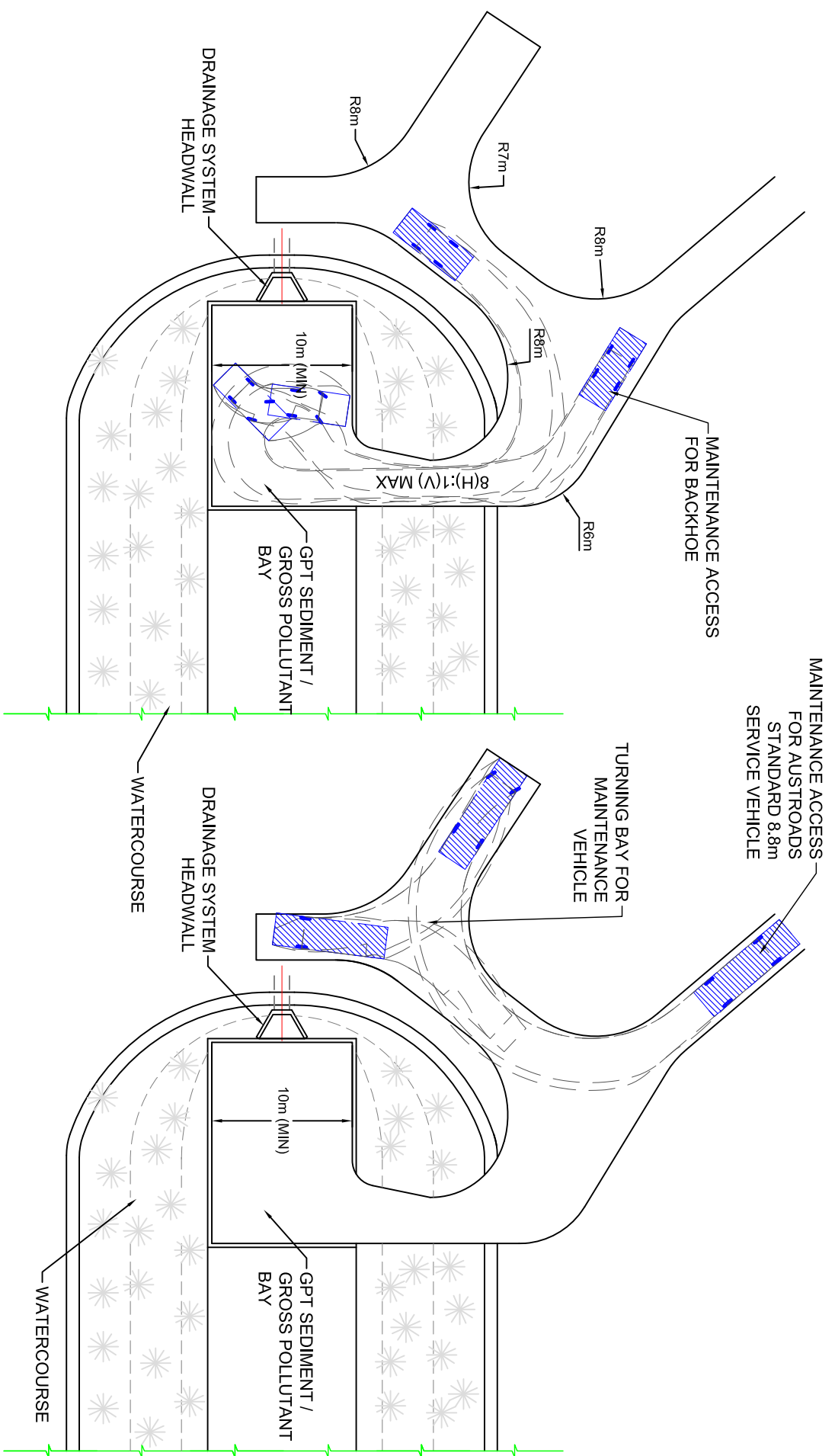

**TYPICAL BACKHOE ACCESS**

**TYPICAL SERVICE VEHICLE ACCESS**

|                                       |           |   |  |             |             |          |   |
|---------------------------------------|-----------|---|--|-------------|-------------|----------|---|
| DRAWING TITLE                         |           |  |  | DRAWING No: | MBRC - 2111 | VERSION: | A |
| MAINTENANCE ACCESS - GPT ABOVE GROUND |           |   |  | DRAWING No: | MBRC - 2111 | VERSION: | A |
| VERSION                               | DATE      | COMMENTS  |  |             |             |          |   |
| A                                     | 25 FEB 13 | FIRST ISSUE   |  |             |             |          |   |

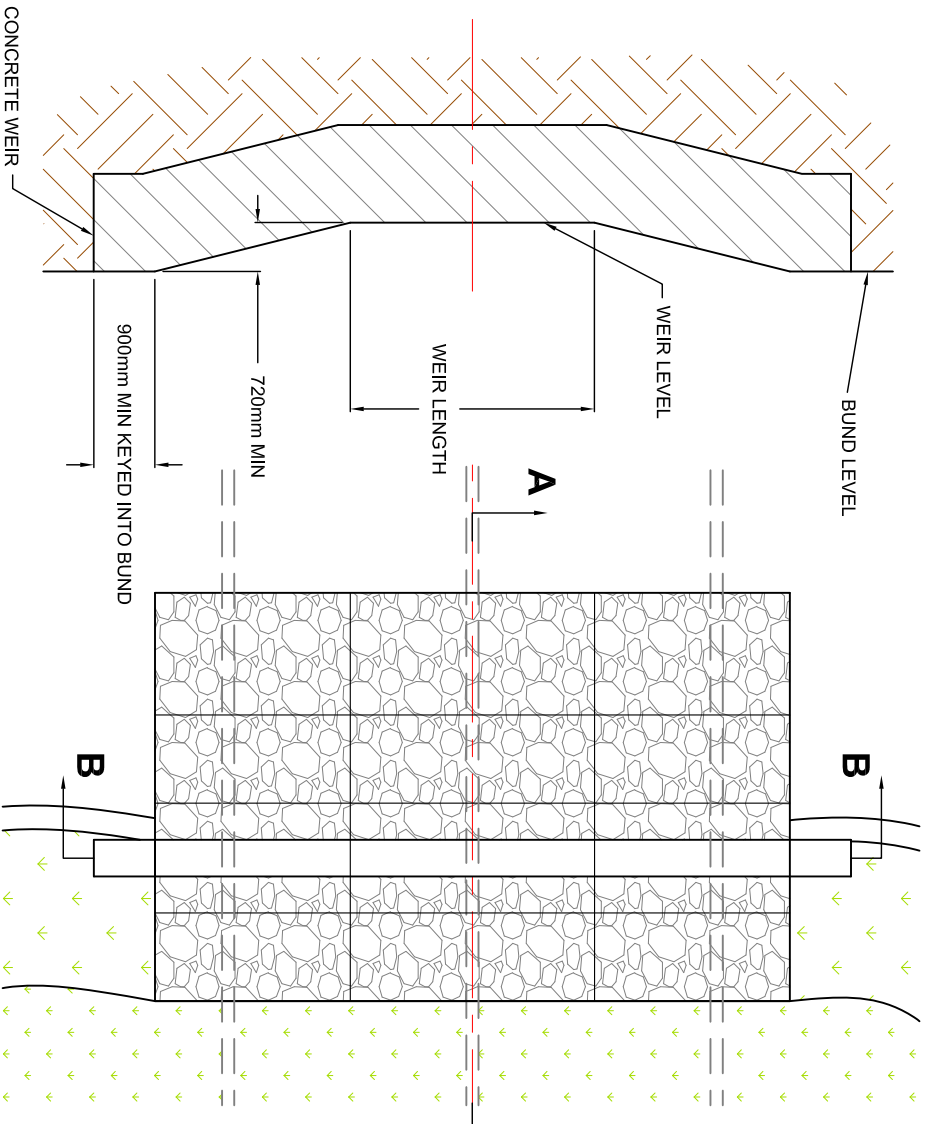

**PLAN**

- NOTES**
1. FOR GENERAL DESIGN AND CONSTRUCTION NOTES REFER TO MBRC-2103.
  2. CONCRETE WEIR - 300 WIDE X 800 HIGH CONCRETE (N32) WITH SL81 MESH PLACED CENTRALLY.
  3. INSITU MATERIAL TO BE TESTED AND APPROVED BY GEOTECHNICAL ENGINEER PRIOR TO WEIR CONSTRUCTION.
  4. GROUDED STONE PITCHING - STONES 75-100, 300 THICK ON FILTER CLOTH, REFER NOTE 4. REFER LANDSCAPE DRAWINGS AND PROJECT DRAWINGS FOR PLANT SPECIFICATION AND DETAILS. GEOTECHNICAL ENGINEER TO CONFIRM COMPACTION REQUIREMENTS FOR BUND SUBSOIL. OPTION TO DRILL 100 CORES THROUGH TO SUBSOIL TO PROVIDE VOIDS FOR PLANTING (SUBJECT TO FLOW VELOCITIES AND LOCAL GOVERNMENT REQUIREMENTS). REFER LANDSCAPE DRAWINGS FOR PLANTING DETAILS.
  5. FOR EXTENT AND DETAILS OF SCOUR PROTECTION REFER TO PROJECT DRAWINGS.
  6. BUND LEVEL. REFER TO PROJECT DRAWINGS FOR MINIMUM FREEBOARD REQUIREMENTS. BUND LEVELS MUST BE NOTED ON PROJECT DRAWINGS.
  7. DRAWING DETAIL BASED ON THE INSTITUTE OF PUBLIC WORKS ENGINEERING AUSTRALIA QUEENSLAND DIVISION INC. STANDARD DRAWINGS.
  8. ALL DIMENSIONS IN MILLIMETRES UNLESS SPECIFIED OTHERWISE.

**SECTION B-B**

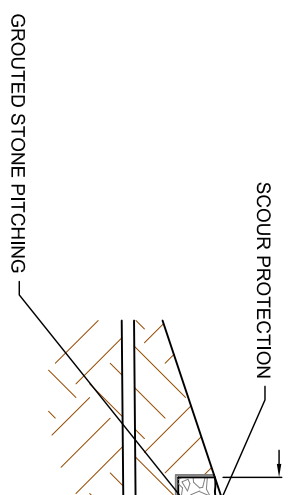

**SECTION A-A**

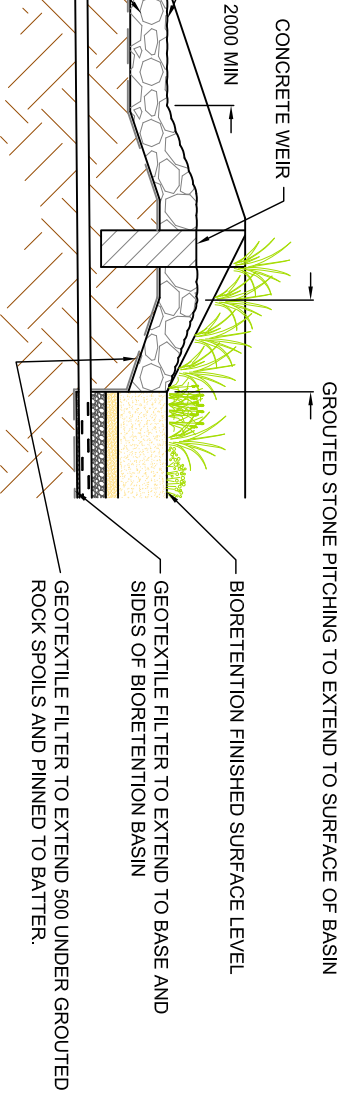

|         |           |             |
|---------|-----------|-------------|
| VERSION | DATE      | COMMENTS    |
| A       | 25 FEB 13 | FIRST ISSUE |
|         |           |             |
|         |           |             |
|         |           |             |



|                        |             |
|------------------------|-------------|
| DRAWING TITLE          |             |
| HIGH FLOW WEIR DETAILS |             |
| DRAWING No:            | MBRC - 2112 |
| VERSION:               | A           |



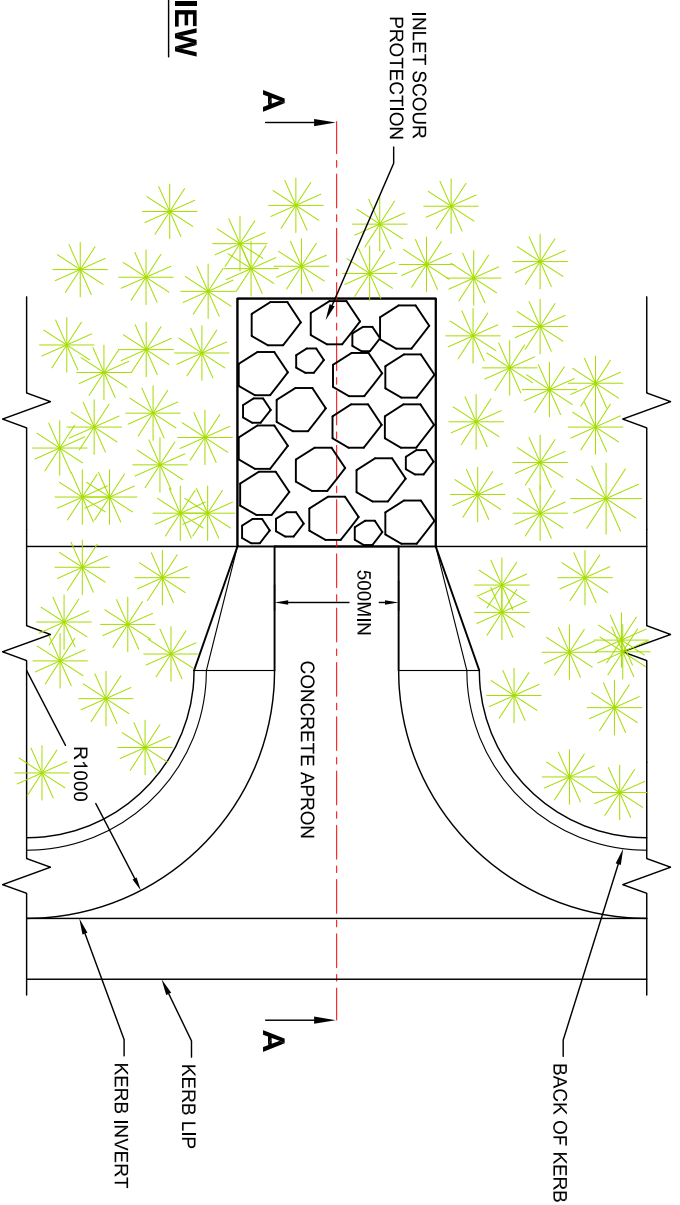

**PLAN VIEW**

- NOTES**
1. FOR GENERAL DESIGN AND CONSTRUCTION NOTES REFER TO MBRC-2103.
  2. DRAWING DETAIL BASED ON THE INSTITUTE OF PUBLIC WORKS ENGINEERING AUSTRALIA QUEENSLAND DIVISION INC. STANDARD DRAWINGS
  3. ALL DIMENSIONS IN MILLIMETRES UNLESS SPECIFIED OTHERWISE.

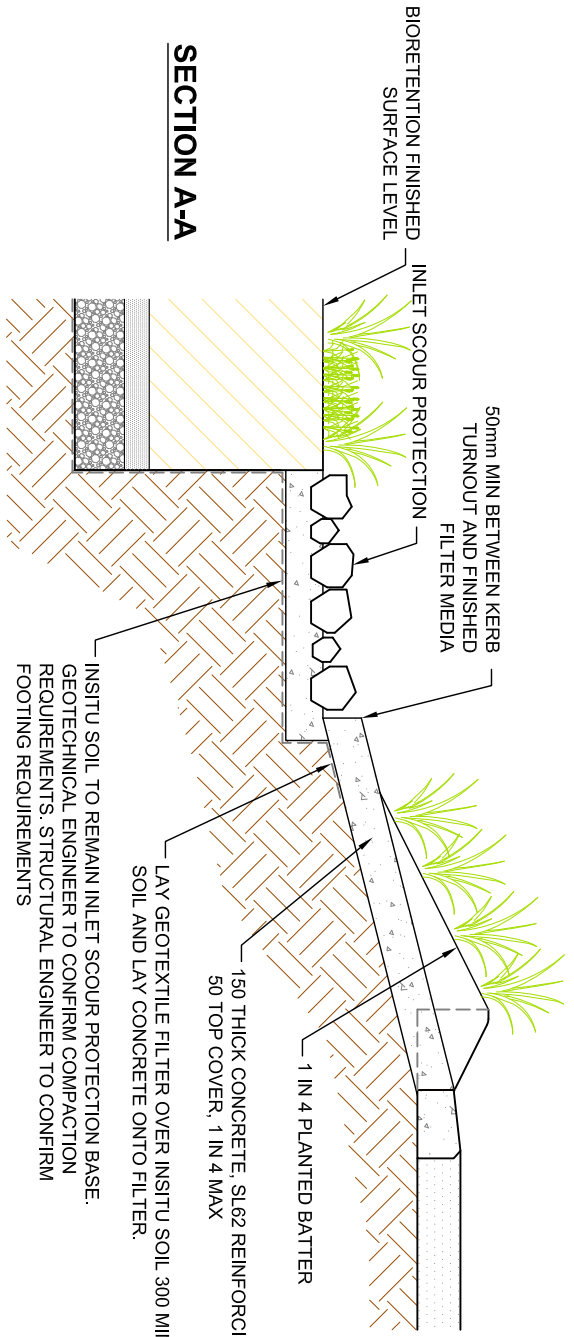

**SECTION A-A**

|         |           |             |
|---------|-----------|-------------|
| VERSION | DATE      | COMMENTS    |
| A       | 25 FEB 13 | FIRST ISSUE |
|         |           |             |
|         |           |             |
|         |           |             |



|               |                        |
|---------------|------------------------|
| DRAWING TITLE | SMALL SEDIMENT FOREBAY |
| DRAWING No:   | MBRC - 2113            |
| VERSION:      | A                      |

|         |           |             |
|---------|-----------|-------------|
| VERSION | DATE      | COMMENTS    |
| A       | 25 FEB 13 | FIRST ISSUE |

|         |           |             |
|---------|-----------|-------------|
| VERSION | DATE      | COMMENTS    |
| A       | 25 FEB 13 | FIRST ISSUE |



|             |             |          |   |
|-------------|-------------|----------|---|
| DRAWING No: | MBRC - 2114 | VERSION: | A |
|-------------|-------------|----------|---|

DRAWING TITLE  
**LARGE BIORETENTION  
 SEDIMENT FOREBAY**

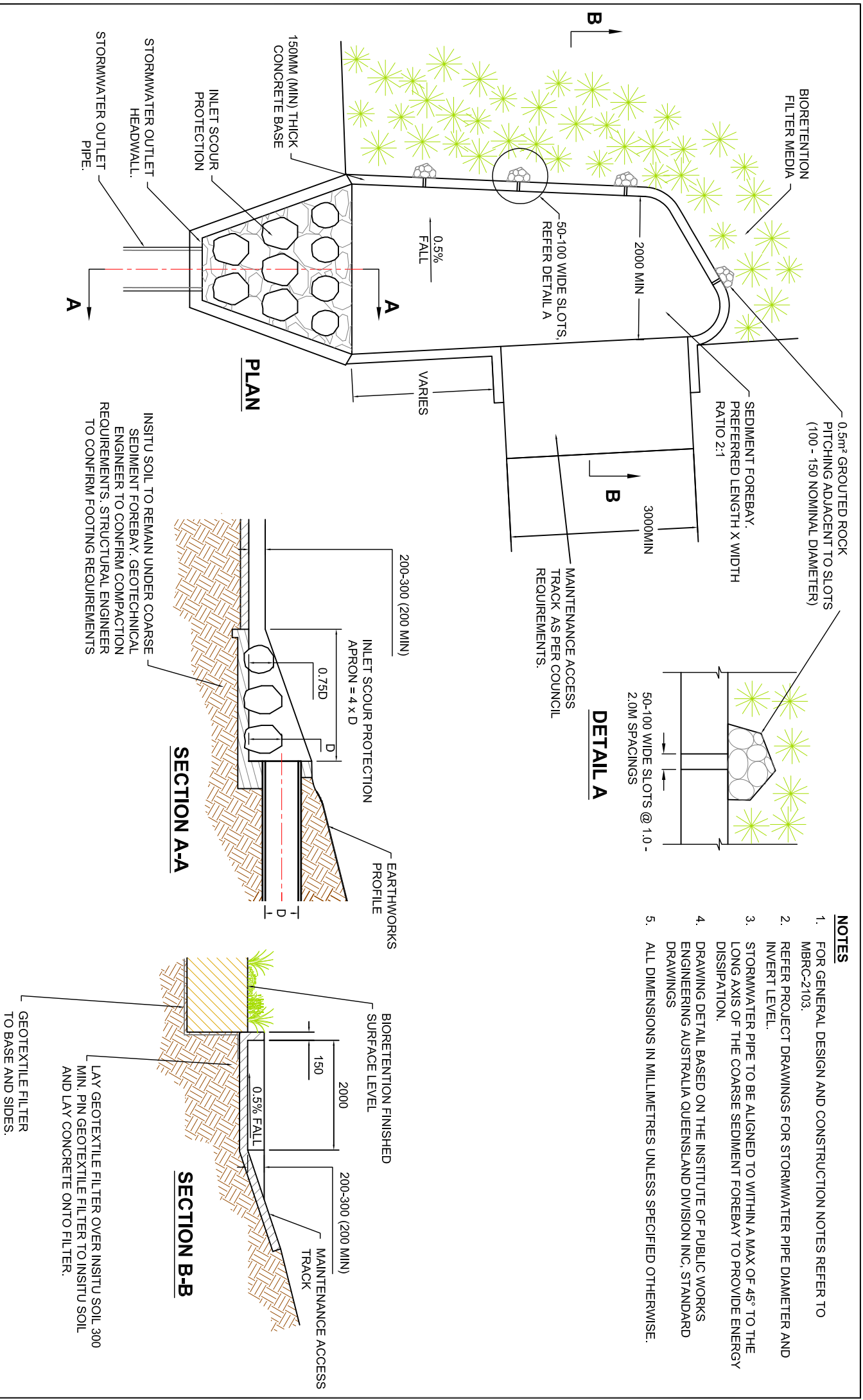

**NOTES**

- FOR GENERAL DESIGN AND CONSTRUCTION NOTES REFER TO MBRC-2103.
- REFER PROJECT DRAWINGS FOR STORMWATER PIPE DIAMETER AND INVERT LEVEL.
- STORMWATER PIPE TO BE ALIGNED TO WITHIN A MAX OF 45° TO THE LONG AXIS OF THE COARSE SEDIMENT FOREBAY TO PROVIDE ENERGY DISSIPATION.
- DRAWING DETAIL BASED ON THE INSTITUTE OF PUBLIC WORKS ENGINEERING AUSTRALIA QUEENSLAND DIVISION INC. STANDARD DRAWINGS
- ALL DIMENSIONS IN MILLIMETRES UNLESS SPECIFIED OTHERWISE.

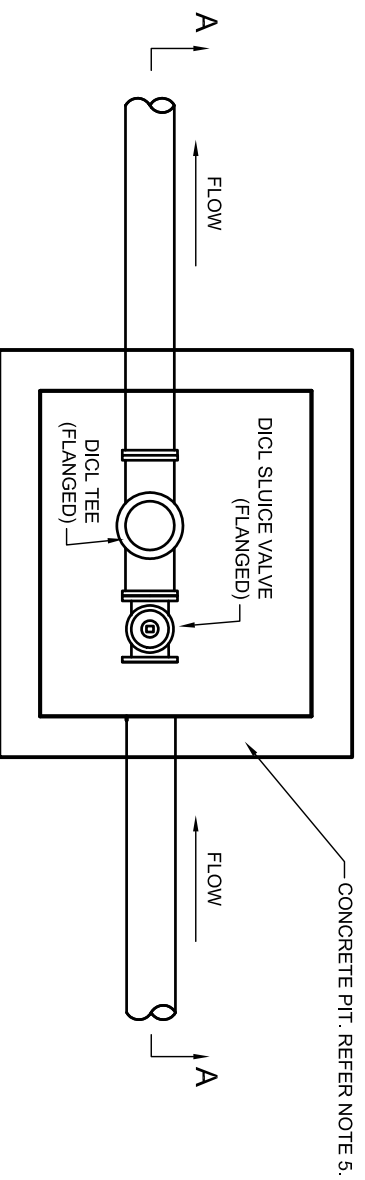

**PLAN**

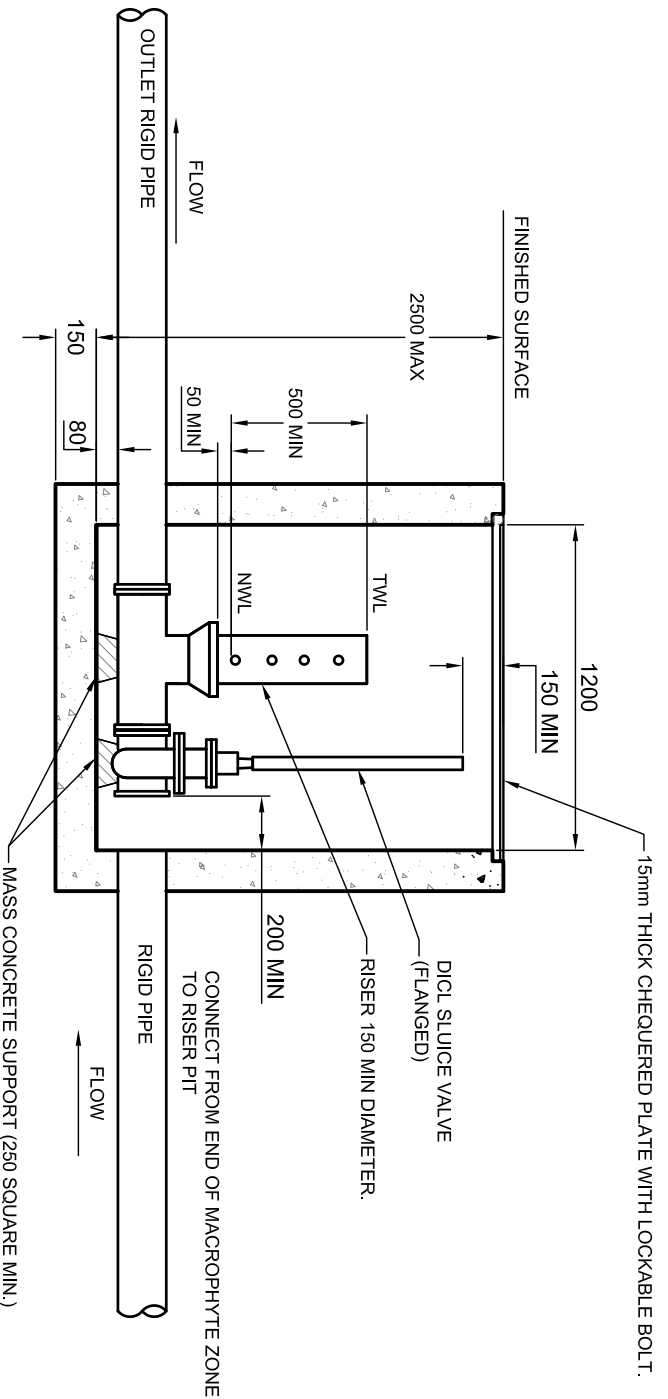

**SECTION A-A**

**NOTES**

1. FOR GENERAL DESIGN AND CONSTRUCTION NOTES REFER TO MBRC-2103.
2. REFER TO PROJECT DRAWINGS FOR RIGID PIPE DIAMETER AND INVERT LEVEL.
3. DNCL SLUICE VALVE. REFER PROJECT DRAWINGS FOR VALVE SIZE. VALVE TO REMAIN IN CLOSED POSITION FOR NORMAL OPERATION. VALVE TO BE OPENED TO LOWER THE WATER LEVEL FOR MAINTENANCE OF THE WETLAND, BIORETENTION SYSTEM OR SEDIMENTATION BASIN.
4. RISER RIGID PIPE CL16. REFER TO PROJECT DRAWINGS FOR HOLES SIZE AND LOCATIONS. HOLE SIZE AND NUMBER AS PER RELEVANT SECTION OF "WATER SENSITIVE URBAN DESIGN TECHNICAL DESIGN GUIDELINES" (WATER BY DESIGN).
5. FOR PITS OVER 2500MM IN DEPTH, REFER PROJECT DRAWINGS FOR PIT DIMENSIONS AND REINFORCING DETAILS.
6. CONCRETE N25 IN ACCORDANCE WITH AS 1379 AND AS 3600.
7. LID AND FRAME TO BE HOT DIP GALVANISED AFTER FABRICATION TO AS 1650.
8. DRAWING DETAIL BASED ON THE INSTITUTE OF PUBLIC WORKS ENGINEERING AUSTRALIA QUEENSLAND DIVISION INC. STANDARD DRAWINGS.
9. ALL DIMENSIONS IN MILLIMETRES UNLESS SPECIFIED OTHERWISE.

|         |           |             |
|---------|-----------|-------------|
| VERSION | DATE      | COMMENTS    |
| A       | 25 FEB 13 | FIRST ISSUE |



|               |                               |
|---------------|-------------------------------|
| DRAWING TITLE | WETLAND LOW FLOW RISER OUTLET |
| DRAWING No:   | MBRC - 2115                   |
| VERSION:      | A                             |