

ELEVATION
Scale A

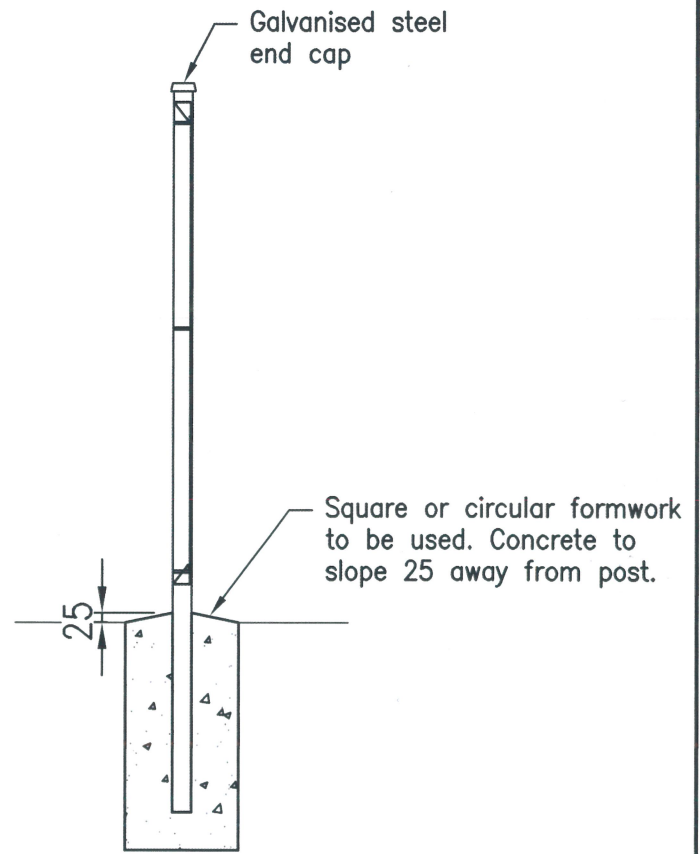

DETAIL
Scale A

NOTES

1. Gate and end posts to be 65x65x2 galvanised steel section to AS 1163.
2. Intermediate posts to be 50x50x2 galvanised steel section to AS 1163.
3. Panels to be fixed to posts using standard galvanised clips and galvanised M8 bolts.
4. Galvanizing to AS 1214 and AS 4792.
5. Panels and posts to be powder coated black or as shown on project drawings.
6. Concrete N25 minimum in accordance with AS 1379 and AS 3600.
7. Posts are to be vertical. Raked panels are available for slopes up to 1 in 5.
8. Nuts to be spot welded to bolts as an anti-theft deterrent.
9. All dimensions are in millimetres unless shown otherwise.
10. 100mm wide reflective tape to be applied to end posts where vehicle traffic conflict.
11. This type of fencing is not suitable for use in a coastal environment.

REVISIONS	INIT	DATE
E		
D		
C		
B		
A	TC	8/17
X	TC	06/17

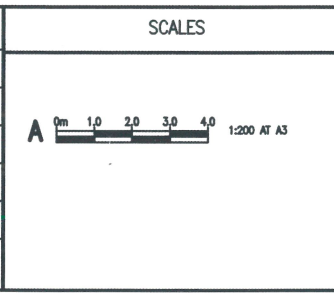

Drawn	TC	Date	07/17
Coordinator	PP	Date	07/17
AUTHORISED SYD JERRAM 03/07/17 Manager Integrated Transport Planning & Design RPEQ 6872			

**PEDESTRIAN FENCE
POWDER COATED WELDED MESH PANELS**



DRG No. **SF-1507**

ORIGINAL SIZE **A3** REVISION **A**