

MANGO HILL INFRASTRUCTURE DEVELOPMENT CONTROL PLAN

Sector Plan 043-4000

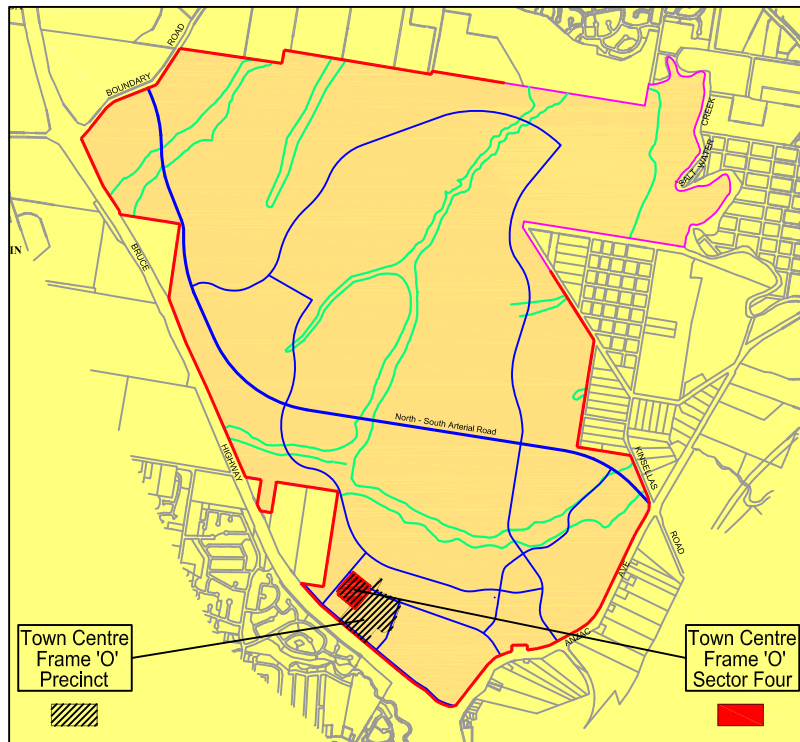

Town Centre Frame 'O' Precinct
Town Centre Frame 'O' Sector Four

26 August 2011

MANGO HILL INFRASTRUCTURE DEVELOPMENT CONTROL PLAN

Sector Plan No. 043-4000

For

**Town Centre Frame “O” Sector Four
North Lakes Drive and Mason Street**

**Town Centre Frame “O” Precinct
North Lakes Development**

26 August 2011

Contents

1.0 Introduction and Statutory Context.....	4
2.0 Land Use Rights.....	4
3.0 Development Requirements & Guidelines.....	5
3.1 Introduction.....	5
3.2 Development Concept	5
3.3 Development Requirements.....	6
3.4 Design & Siting Measures	6
3.5 Landscaping/Townscaping	12
3.6 Carparking, Service Areas & Loading Docks	14
3.7 Signage	16
4.0 Environmental Management	18
5.0 Subdivision Requirements	18
6.0 Infrastructure	18
6.1 Infrastructure To Be Provided	18
6.2 Infrastructure Affected Or Required By Development Of The Sector.....	20
6.3 How The Required Infrastructure Relates To The Infrastructure Agreements	21
7.0 Detailed Infrastructure Program.....	21
7.1 Estimated Date For Provision Of Infrastructure	21
7.2 Intended Provider.....	21
7.3 Other Works Dependent On Infrastructure Provision	21
7.4 Other Relevant Information.....	22

Contents

FIGURES:

Figure		Reference	Date
1.	Planning Context	TCFOSectorFig1	June 2011
2.	Cadastral Boundaries	TCFOSectorFig2	June 2011
3.	Precinct Plan Map	TCFOSectorFig3	June 2011
4.	Sector Plan Map	TCFOSectorFig4	June 2011
5.	Sector Landscape Plan	TCFOSectorFig5	June 2011
6.	Indicative Plan of Subdivision	TCFOSectorFig6	July 2011
7.	Road Layout	TCFOSectorFig7	June 2011
8.	Water Supply Headworks	TCFOSectorFig8	June 2011
9.	Sewerage Headworks	TCFOSectorFig9	June 2011

APPENDICES:

- A. Final Specification of Land Use for the Sector
- B. Plant List
- C. Bicycle Parking Requirements
- D. Town Centre Signage Guidelines
- E. Proposed Metes and Bounds Description
- F. Streetscape / Character Images

1.0 Introduction and Statutory Context

- 1.1 The Mango Hill Infrastructure Development Control Plan (DCP) provides a process for development of land in the DCP area and for the creation of a Sector within a Precinct and the preparation by the Principal Developer of a Sector Plan in accordance with the relevant provisions of the DCP.
- 1.2 This document constitutes the Sector Plan for the **Town Centre Frame 'O' Sector 043-4000** (Sector Plan).
- 1.3 The location of the Sector within the DCP area is shown on *Figure 1 – Planning Context*. As illustrated on *Figure 2 – Cadastral Boundaries*, the Sector is bounded by:
- (i) North Lakes Drive to the north;
 - (ii) Sector Plan 043-1000 to the east;
 - (iii) Staypelton Street; and
 - (iv) Mason Street to the west.
- 1.4 The location of the Sector within the Precinct Plan area is shown on *Figure 3 – Precinct Plan Map*.
- 1.5 This Sector Plan is the code of development for the land in the Sector. In the event that this Sector Plan does not provide development requirements, then the Planning Scheme provisions relevant to the particular form of development apply.
- 1.6 The DCP, approved Precinct Plans and approved Sector Plans are to be read in conjunction with the planning scheme and Council's local laws, policies and codes and to the extent the DCP, Precinct Plans and Sector Plans do not modify provisions of the Council's planning scheme, local laws, policies and codes they will apply to the DCP area.
- 1.7 To the extent the provision of Council's planning scheme, local laws, policies or codes are modified by the DCP, Precinct Plans or Sector Plans, then the provisions of the DCP, the Precinct Plans or Sector Plans will prevail.
- 1.8 Development in the Sector must comply with the provisions of the Sector Plan.

2.0 Land Use Rights

The final specification of land use rights for land in this Sector is contained in *Appendix A – Final Specification of Land Use for the Sector*.

3.0 Development Requirements & Guidelines

3.1 INTRODUCTION

Clause 2.4.2 of the DCP states that a Sector Plan must specify the requirements for development and car parking and the guidelines for design and siting, landscaping and signage for land in the Sector.

3.2 DEVELOPMENT CONCEPT

The development concept for this Sector is for generally medium density, low-rise commercial development. It is anticipated that this Sector may provide hardware centre and/or ancillary and incidental uses, retail related uses (for example, fast-food) and/or vehicle sales yard that integrate with the overall Town Centre with respect to functional outcomes and urban design. The built form and design within this Sector should complement that further east along North lakes Drive. Alternatively built form and design may complement the larger scale retail development located in the Town Centre Core.

Access to the Sector is to be from the western frontage via a left in left out access arrangement along Mason Street. Secondary access to the site may also be provided via the access easement, located along the western boundary of Sector 043-1000, at the signalised intersection on North Lakes Drive.

Development in the Sector should:

- (i) ensure connectivity, integration and strong functional and architectural relationships with the commercial developments within the Sector, Precinct and the balance of the Town Centre;
- (ii) ensure that car parking areas in the Sector are enhanced by landscaped vehicular and pedestrian links. Potential conflict points between vehicular and pedestrian movements are to be minimised through considerate design; and
- (iii) where possible, provide opportunities for shared use of car parking and service areas between different developments and uses.

Figure 4 – Sector Plan Map is one illustration of how these requirements may be satisfied.

3.3 DEVELOPMENT REQUIREMENTS

3.3.1 In respect of every development in this Sector which involves the erection of a building, the person who undertakes that development or uses the site must as part of that development or use, unless already provided:

- (i) construct a full width pedestrian pavement to Council's specification for the full length of those road frontages required by Council to the development site;
- (ii) construct concrete kerb and channeling to the Council's specification for the full length of each road frontage to the development site;
- (iii) construct reinforced concrete industrial crossings to the Council's specification from the kerb and channeling to the property alignment of the development site at approved locations where vehicular access to the development site is required;
- (iv) provide drainage work specified by the Council as necessary in connection with the works set out above including debris traps where drainage discharges directly or indirectly to the lake and/or waterway system;
- (v) provide reticulated sewerage and water supply adequate for the purpose of the development by connection to the Council's services in accordance with the requirements of the Council; and
- (vi) bear the cost of any alteration necessary to public utility mains, services or installations involved in the construction of the works referred to in this clause.

3.3.2 In respect of every development in this Sector the person who undertakes that development or uses the site must:

- (i) have all buildings designed by a registered architect and all landscaping designed by a qualified landscape architect;
- (ii) not impose a load on any public utility including the disposal of wastes, greater than that which is contemplated by the provisions of this Sector Plan; and
- (iii) not cause interference with the amenity of the area by the operation of machinery or electrical equipment, or from light, noise, vibration, smell, fumes, smoke, vapour, steam, soot, ash, grit, oil, dust, waste water, waste products, electrical interference or otherwise.

3.4 DESIGN & SITING MEASURES

3.4.1 Building Setbacks

Building setbacks are to:

- (i) be generally no less than three (3) metres from all street frontages or if set back further, 3 metres landscaping should be provided to screen parking and other use areas; and
- (ii) if integrated with development in adjoining allotments, be built up to the side and rear boundary of the Sector.

3.4.2 Site Coverage

Site coverage and associated plot ratio are not restricted, provided the following elements are appropriately and adequately addressed by the design of the development:

- (i) architectural articulation and an appropriate level of design;
- (ii) attractive frontages;
- (iii) development is in context with, and visually compatible with the appearance of, any neighbouring buildings;
- (iv) pedestrian facilities including pedestrian shelters are provided at ground level; and
- (v) sufficient on-site car parking is provided.

3.4.3 Building Design

Buildings within the Sector must:

- (i) be generally in accordance with the measures referred to in section 5.4 of the DCP;
- (ii) be in context with and visually compatible with the height, scale and bulk of surrounding development and streetscape patterns;
- (iii) not exceed three (3) storeys in height;
- (iv) include a combination of design elements such as projections, recesses, openings and variations in light/shade and three (3) dimensional form to reduce building bulk, scale and mass;
- (v) integrate building design, an outdoor forecourt to the building, landscaping, pedestrian movement along the front of the building, car parking and manoeuvring aisles (including any proposed drive thru lanes) to ensure an attractive presentation to all road frontages and external pedestrian thoroughfares;
- (vi) orientate main entrances to address the street frontage or outdoor forecourt and clearly identify and define the main entry, well-lit pedestrian access and vehicular access to the street environment;
- (vii) allow sensitive environmental responses to slope, access and integration requirements;
- (viii) be designed with attractive roofscapes that complement the overall building design and include varying elements for visual interest;
- (ix) ensure overall unity throughout the Sector, as well as a relationship with the broader DCP area, while providing sufficient flexibility for corporate identification and marketing purposes;
- (x) incorporate materials and colours that will not be highly reflective in order to avoid unreasonable glare nuisance to surrounding development;
- (xi) incorporate horizontal and vertical variations in the façade and attractive facades and entries; and

- (xii) be designed to include architectural responses to the South-East Queensland climate. For fast-food restaurant uses this includes the use of external shade structures (such as roof cover, canopies and/or awnings) over outdoor dining areas, play areas and outdoor servery areas.

3.4.3.1 Building Design Guidelines

Building design within the Sector is encouraged to:

- (i) be of low to medium rise, with a maximum height of three (3) storey's;
- (ii) include innovative contemporary building design derivative from Queensland building traditions, and designed to suit the climate, light and local culture;
- (iii) be designed to be multi-purpose and easily adapted for future changes;
- (iv) ensure that buildings relate physically and functionally with each other in terms of their architecture, location of major entries and any changes of level across the Sector; and
- (v) ensure that the design and location of any buildings or structures within the Sector take account of:
 - (a) topography and the preference to minimise site earthworks;
 - (b) drainage;
 - (c) soil conditions;
 - (d) services;
 - (e) orientation towards focal points and aspect to achieve energy savings;
 - (f) microclimate considerations;
 - (g) pedestrian movement patterns;
 - (h) vehicular access to avoid or minimise the conflict points with pedestrians;
 - (i) streetscape and landscape design;
 - (j) adjoining developments in terms of design;
 - (k) minimising the effect of overshadowing on pedestrian areas;
 - (l) the functioning of the internal service road;
 - (m) landscape screening of retaining walls and other elements with low visual amenity; and
 - (n) views and vistas to prominent built and topographic features.

3.4.3.2 Material, Finish and Colour Guidelines

Building design within the Sector is encouraged to:

- (i) reflect a distinctive contemporary architectural style, with buildings sharing a palette of compatible finishes, colours and details that create a strong sense of place;

- (ii) use materials and colours relating to those in the local environment, including the use of key character elements, for example, block stone work may be incorporated into the base of buildings to relate to the stone detailing within North Lakes. Other key character elements may include the use of timber detailing, earthy tones, heavy plinth bases and feature species planting;
- (iii) incorporate brighter colour accents for minor detail elements such as window and door frames, columns, handrails, ornamental features and signage details;
- (iv) include the integrated use of elements such as timber, glass and tin; and
- (v) incorporate materials that:
 - (a) are robust, durable and resistant to vandalism;
 - (b) present a suitable finish to pedestrian areas;
 - (c) incorporate walls which present as solid and permanent elements;
 - (d) are of a high quality, clean and free of defects;
 - (e) are low maintenance, resulting in minimum use of detergents for cleaning; and
 - (f) assist with thermal performance and energy efficiencies, where practicable.

3.4.3.3 Design for Climate and Energy Efficiency Guidelines

Building design within the Sector is encouraged to:

- (i) for any other proposed use not listed in 3.4.3(xii) above, include the use of external shade structures, ventilated spaces, overhangs and screens to allow enjoyment of the outdoors while also providing relief from the sun, wind and rain;
- (ii) maximise ventilation by taking advantage of prevailing breezes and the use of adequate and effective insulation materials in roof cavities and wall spaces of buildings in order to minimise demands for energy required for air-conditioning;
- (vi) articulate and shade external walls, and particularly the longer external walls, with eaves, overhangs, sills or other treatments to reduce the exposure to direct sunlight, heat and glare, while windows in external walls should be recessed or shaded wherever possible to achieve energy savings;
- (vii) restrict the use of highly reflective materials on external walls or windows as a means of minimising energy requirements and excessive sunlight, glare and heat into adjoining developments;
- (viii) incorporate the use of gas or solar hot water heaters and solar energy devices;
- (ix) implement energy efficient management systems for the building;
- (x) where possible, orientate buildings to respond to westerly sun exposure, northerly exposure and solar access in the winter, potential impacts of cold westerly winds in winter and limited cooling breezes from the south in summer; and
- (xi) design, site and landscape car parking areas to reduce the impacts of reflected heat and glare into adjacent buildings, and to reduce the effects of heat storage during summer months.

3.4.4 Safety and Crime Prevention

The design and siting of any structures, landscaping, buildings and public spaces must:

- (i) avoid obscured corners and narrow or dead-end alleys;
- (ii) maximise the opportunity for casual surveillance of public spaces and car parking areas from surrounding buildings, roads and pedestrian areas;
- (iii) include lighting of public places; and
- (iv) include for a use with a gross floor area of 2,500m² or more, an Environmental Design assessment such as Crime Prevention Through Environmental Design (CPTED) or similar crime prevention safety audit, which must be undertaken by applicants during the design phase and properly taken into account in the final design of the project. A copy of the assessment shall be provided to Council at the time of lodging each development application for a Material Change of Use. This assessment is to have due regard to the design and maintenance of buildings and external areas within the Sector, as well as the factors outlined in this sub-section.

3.4.5 Lighting & Glare

Lighting and Glare Management within the Sector must:

- (i) wherever possible, architectural floodlighting of a building or space is achieved through the integration of the luminaries into the fabric of the building;
- (ii) ensure lighting systems are designed to prevent direct and/or reflected glare to surrounding areas. This applies particularly to disabling and uncomfortable glare to pedestrian and vehicular movement or at entrances, steps, stairs and pedestrian paths;
- (iii) where provided within landscaped areas, the choice and location of lighting must allow for plant and tree growth and, conversely, not become obscured as the landscape matures;
- (iv) include safety lighting in open space and car parking areas which may be used at night-time;
- (v) ensure permanent strobe, laser, flashing, oscillating, moving or alternating lights are not permitted in locations within the Sector where they are likely to cause a nuisance;
- (vi) have regard to the efficiency of energy consumption in the design of lighting systems; and
- (vii) comply with the requirements of AS4282 – *Control of Obtrusive Effects of Outdoor Lighting*.

3.4.6 Plant & Equipment

The design and siting of plant and equipment must comply with the following requirements:

- (i) all air conditioning and ventilation plant and other equipment located on the roof or externally around the building are to be treated as an integral part of the building form and be suitably screened from view to match with surrounding materials;
- (ii) where lift motor rooms, plant rooms and the like are proposed, they are to be treated as an integral part of the building form in order to create a coherent roofscape;
- (iii) environmental management structures or control devices, such as gross pollutant traps, waste disposal bins, flues and the like are to be designed so as not to detract from the overall visual character of the town centre or the immediate area;
- (iv) contain design elements and buffer treatments to control any obtrusive effects where it is likely to adversely affect residential amenity, visual aesthetics, public safety and traffic safety;
- (v) unsightly areas used for storage, electrical, air-conditioning or other building plant, refuse bins, tanks, security fencing or enclosures, or similar "back of house" storage areas are to be adequately screened and/or located so as not to be visible from the street.
- (vi) if necessary, adopt effective air pollution mitigation measures to comply with the *Environmental Protection Act, Environmental Protection Policy (Air)* and other relevant legislation in relation to dust, smoke, fumes and gases, where necessary; and
- (vii) if necessary, adopt effective noise pollution mitigation measures to comply with the *Environmental Protection Act, Environmental Protection Policy (Noise)* and other relevant legislation, where necessary.

3.4.7 Telecommunications Equipment

Telecommunications equipment is to be:

- (i) generally co-located with other telecommunications equipment installed in the Sector;
- (ii) constructed in a form complementary to the façade and roofline of the building on which it is to be mounted; and
- (iii) where possible, coloured so as to blend in with the background of the building on which it is to be mounted.

3.4.8 Regrading

The earthworks approach for the Sector must:

- (i) ensure that changes of level at the site boundary allow non-discriminatory access to each allotment from the road frontage/s and to adjoining allotments;
- (ii) take into account the efficient management of earthworks;
- (iii) be generally in accordance with surrounding approved Sector Plans; and

- (iv) achieve a high level of functional and visual integration between the Town Centre Core and the Town Centre Frame.

3.5 LANDSCAPING/TOWNSCAPING

3.5.1 Landscape/Townscaping Concept

The landscape framework for the Sector is represented by the design principles shown indicatively on *Figure 5 – Sector Landscape Plan*.

3.5.2 Character

The key purpose of the Sector is the functionality of the commercial uses. Landscaping should therefore be designed to create an attractive, yet functional and highly permeable environment. The landscape character of the Sector is to be established by integrating plantings with the street lighting, furnishings, paving treatments, built form, materials and colours of development in the Sector.

3.5.3 Requirements

Landscaping in the Sector must:

- (i) correspond with the design principles illustrated on *Figure 5 – Sector Landscape Plan*;
- (ii) generally achieve the landscape character described above and the landscape concept described in section 4.2 of the Precinct Plan;
- (iii) provide a minimum landscaped strip of three (3) metres to all street frontages and a 1.5 metre wide landscaped strip in front of any side or rear fencing;
- (iv) where retaining walls or batters are required along the street frontages the retaining wall is to be located centrally within the landscape buffer and be landscaped at the top and toe of the wall to reduce the impact of the wall if visible from a street;
- (v) be designed to complement and integrate with the landscaping and design character of adjoining Sectors and Precincts;
- (vi) include canopy trees, planted by the Principal Developer, generally with a minimum clear trunk of 1.8 metres planted at informal intervals within the road reserve. Street trees are intended to provide visual continuity to the street, reduce the road scale and provide shade to on-street car parking and adjacent pedestrian areas;
- (vii) reduce the appearance of an expanse of carparking areas by providing advanced shade trees at the rate of not less than one (1) tree per six (6) parking spaces;
- (viii) provide adequate landscaped areas so as to create a landscape setting and passive recreation space for development;
- (ix) allow for pedestrian linkages and landscape planting extending from entry points to development sites within the Sector to connect, where possible,

- through car park areas to the pedestrian pathway associated with the circulation road;
- (x) be employed to reduce reflected glare from building facades;
 - (xi) not compromise the safety of vehicles accessing sites within the Sector or in surrounding development;
 - (xii) be capable of efficient and effective maintenance;
 - (xiii) generally frame entry areas to sites;
 - (xiv) screen services such as electricity substations and transformers in a way that does not affect the streetscape;
 - (xv) delineate between the pedestrian and vehicular environments, as well as to provide some relief from headlight glare and visual monotony;
 - (xvi) screen car parking areas from roads and other areas readily accessible to the public;
 - (xvii) ensure retaining walls are to be screened by landscaping at the top and toe of the wall to ensure the presentation to the street is predominantly that of landscaping; and
 - (xviii) ensure retaining walls are not to exceed 3.0 metres in height without terracing to provide a minimum width of 0.5 metres of landscaping. Fences atop of retaining walls are to be further setback behind a landscape screen to ensure the presentation to the street is predominantly of landscaping.

3.5.4 Fencing

The requirements for fencing within the Sector are set out below:

- (i) if fencing is proposed to side and rear boundaries, the height of fencing must not exceed 1.8 metres and must be transparent through use of spaced timber palings or similar;
- (ii) fencing is not to be provided to any street frontage unless integrated with the landscaping to these frontages and set back at least 2 metres from the frontage. Fencing may not exceed 1.2 metres and needs to be at least 75% transparent; and
- (iii) any fencing visible from the street frontage is to be black pool style fencing and any security lighting, security fencing, enclosures, signage posts, or other such street furniture is to have a black powder coated finish.

3.5.5 Plant Species Guidelines

Planting within the Sector is encouraged to incorporate:

- (i) plant species themes that are consistent and complementary to surrounding development. The species of trees, shrubs, and groundcovers used within the Sector should be selected from the Plant List included in **Appendix B - Plant List**. Plants of similar characteristics may be substituted for a species in the Plant List, if approved by Council. The selection of landscape material is to be cognisant of safety considerations by excluding thorny or poisonous plants that may be hazardous;

- (iii) the use of native species as the predominant plantings to visually reflect the original natural setting of the DCP area, as well as offer benefits of reduced maintenance and water requirements. Exotic and flowering species may be used occasionally as feature planting, to announce entries to the Sector, to provide shade trees in public outdoor spaces, or as accents of colour and texture within the framework of native plant material; and
- (iv) planting densities and heights appropriate for particular areas such as car parking areas, retaining walls and the like are to be shown on a Landscape Plan submitted as part of the Material Change of Use application.

3.6 CARPARKING, SERVICE AREAS & LOADING DOCKS

3.6.1 Carparking

Car parking in the Sector must:

- (i) be in accordance with the Planning Scheme, the DCP and the Council's Design Manual;
- (ii) be controlled to minimise its impact on the surrounding road network, any internal circulation and other development adjacent to the Sector;
- (iii) provide safe pedestrian routes which focus on the connectivity between the individual site, allotments within the Sector, balance of the Town Centre Frame;
- (iv) as part of the total car parking requirements, provide not less than one (1) car park per fifty (50) spaces (or part thereof) for people with disabilities;
- (v) ensure that pedestrian movement areas through car parks to a building are clearly defined;
- (vi) employees bicycle parking spaces and the type of bicycle parking devices are to be generally in accordance with **Appendix C – Bicycle Parking Requirements**;
- (v) one (1) shower cubicle with ancillary change room per ten (10) bicycle spaces required by 3.6.1(vi) above. Facilities may be utilised by both males and females provided adequate privacy and accessibility is ensured for both sexes;
- (vi) customer end use facilities at the rate of one (1) bicycle space per 750m² gfa, with the exception of fast-food restaurant uses where one(1) bicycle space per 50m² gfa is required for customer use. The type of bicycle parking device for customer use is to be in accordance with Class 3, low security level of **Appendix C – Bicycle Parking Requirements**; and
- (vii) if the demand for the bicycle spaces is not consistent with the table contained in **Appendix C**, Council, on a case by case basis, may permit a reduction of the number of end of trip facilities.

3.6.2 Access

The requirements for access are set out below:

- (i) indicative vehicular ingress and egress points from major roads within and adjoining the Sector are limited to the number of access points shown on the Sector Plan Map (Figure 4). However, the location of the access points may vary along the road provided other access restrictions noted on Figure 4 are not compromised;
- (ii) restrictions to vehicular access have been noted indicatively on Figure 4 by the inclusion of the "No vehicular access permitted" designation;
- (iii) vehicular access points should ensure no queuing occurs across pedestrian areas or causes interruption to traffic on the surrounding roads;
- (iv) pedestrian and vehicular access lanes into the Sector are to generally be a maximum width of ten (10) metres and include at least one footpath of a minimum two (2) metres width;
- (v) adequate measures to achieve a high level of public safety on the shared access laneways / driveways is to be provided and, where appropriate, should include:
 - (a) good visibility at all pedestrian crossings and establishing pedestrian priority, where appropriate;
 - (b) distinction in the paving treatments of pedestrian environments such as between intensive pedestrian areas, general footpath areas and pathways within car parking areas;
 - (c) pavement treatments which achieve a very low traffic speed, while permitting easy and even-surfaces for desirable walking conditions for pedestrians;
 - (d) finishes that are in keeping with existing finishes within the road or the road verge;
 - (e) suitable barrier treatments at the entrance points;
 - (f) the provision of continuous pedestrian access between buildings, car parks and pedestrian areas; and
 - (g) the provision of site and building illumination within car park areas, pedestrian areas and along pedestrian paths during the hours of operation of any component of the development and, at other times, by the provision of security lighting.
- (vi) pedestrian access points via car parking areas at the rear of any development should be clearly identified and designed to maximise safety and convenience;
- (vii) access for all people including people with a disability is to be achieved by ensuring that development complies with Council provisions relating to access for people with disabilities; and
- (viii) direct access for emergency vehicles is to be provided to every building within the Sector by the provision of a minimum 3.5 metre clear carriageway width.

3.6.3 Servicing Requirements

Development within the Sector must provide:

- (i) loading zone parking which is to be accessed from the internal vehicle circulation areas;
- (ii) storage for refuse and recyclable materials which are suitably screened from circulation areas;
- (iii) service connection points incorporated into hard and soft landscaping areas;
- (iv) service connections that do not protrude from paving or driveways or cause any hazard for pedestrians or vehicles;
- (v) where appropriate, provide landscaping and other screening devices to undesirable views of service areas, loading bays, refuse areas and plant and machinery, within the Sector and in adjacent Sectors; and
- (vi) sharing of service areas, where possible.

3.7 SIGNAGE

Objectives

To create a distinctive, vibrant, urban landscape appropriate to the Town Centre Frame. To provide a coordinated system of signs that make it easy for the public to orient themselves and identify key attractions and facilities, as well as contributing to the overall visual identity of the Town Centre Frame Precinct.

Signage in the Sector must:

- (i) with respect to signage that identifies the Sector and associated development, be generally integrated with any frontage walls, entry statements or entry structures, if provided. This signage may be located along streets adjoining this Sector;
- (ii) be limited to the indicative primary signage locations noted on the Sector Plan and to signage integrated into any proposed buildings;
- (iii) where appropriate, include directional signage for visitors which may include logos/names of the business;
- (iv) consist of high quality materials, form, scale and proportions and be coordinated to the built form throughout the Sector, while providing sufficient flexibility for corporate identification and marketing purposes;
- (v) ensure that lighting of any signage will not cause a nuisance to drivers or pedestrians;
- (vi) be visible, legible and not result in a cluttered or discordant streetscape;
- (vii) provide limited use of highly reflective finishes;
- (viii) incorporate professional and coordinated graphics;
- (ix) not permit bunting, streamers, sandwich boards and other low-quality, temporary, or opportunistic signs;
- (x) ensure that any support structure or cabling to illuminate signs will not be visible;

- (xi) signs above pedestrian areas must have a minimum clearance of 2.4 metres (refer image 10);
- (xii) signage must not obscure more than 25% of the window on which it is displayed. Any support structure to a sign must not be visible unless treated as an integral part of the visual design;
- (xiii) the use of the North Lakes logo as an integral but subordinate element of the signage and graphics is encouraged, subject to the agreement of the principal developer;
- (xiv) provide for signage which allows for materials and colours related to potential end users' commercial requirements modified as necessary to ensure a degree of harmony between development sites and the overall visual character of the town centre frame;
- (xv) ensures external walls and surfaces of buildings in the town centre frame are compatible with the overall visual character of the town centre core;
- (xvi) ensure overall unity and harmony in major materials and colours in buildings and exterior signage throughout the precinct, while providing sufficient flexibility for corporate identification and marketing purposes;
- (xvii) ameliorate the visual impact of lengthy facades through combination of materials and colours coordinated with building detail treatments and landscaping themes;
- (xviii) ensure that external graphics contributes to the visual character of the Town Centre Frame and are designed as an integral element of the architectural design; and
- (xix) not impact on traffic safety.

In addition, the following measures should be achieved:-

- (a) Key gateway signage statements are to be provided along major road frontages to identify the major uses within the precinct. These gateway signs are to be attractive entry statements and of an appropriate scale and nature;
- (b) Architectural graphics may be designed as part of the architectural character of the major shopping centre;
- (c) Signs should be relative to the scale and proportion of buildings.

3.7.1 Signage Guidelines

- (i) Signage guidelines are included at *Appendix D - Town Centre Signage Guidelines*. The Signage Guidelines are to be taken into consideration, along with other relevant issues, when considering matters regarding signs and architectural graphics of all kinds. They are not to be interpreted as giving rights to any number or types of signage. The guidelines provide for a range of sign types anticipated within the Town Centre Frame. The assessment of a coordinated signage plan will at least address the extent and number of sign to be used; the proximity of a sign to other sign's; and the relationship of the sign with the landscaping.

- (ii) A Coordinated Signage Plan is to be submitted with any development application for Material Change of Use within this Sector. The Coordinated Signage Plan must distinguish between artworks/murals, on-site business advertising, animated signage, and "third party" advertising in terms of sign dimension, location, illumination, and animation on the face of the sign.
- (iii) One principle pylon sign is permitted. The principle pylon sign is to be a maximum height of 5.0 metres on frontage to North Lakes Drive (refer to *Figure 4 – Sector Plan Map*).
- (iv) Secondary pylon signs are to be a maximum height of 3.0 metres and are permitted to other road frontages.
- (v) Signage atop a retaining wall exceeding 2.0 metres is to be limited to a height of 3.0 metres.

4.0 Environmental Management

There is no Environmental Management Plan having application to this Sector.

Management systems for land within the Sector must be implemented to ensure that the Objectives and Performance Indicators referred in the following sections of the Precinct Plan continue to be met throughout the life of the development and the use of the Sector:

- (i) Section 5.1 – Environmental Management Objectives;
- (ii) Section 5.2 – Stormwater Management Objectives; and
- (iii) Section 5.3 – Earthworks Management Objectives.

5.0 Subdivision Requirements

As shown in *Appendix E – Proposed Metes and Bounds Description* the total area of the Sector is 2.98 hectares.

Indicative areas and frontage widths of allotments within the Sector are shown on *Figure 6 - Indicative Plan of Subdivision*.

6.0 Infrastructure

6.1 INFRASTRUCTURE TO BE PROVIDED

The infrastructure required to be provided by the Principal Developer to serve the Sector includes internal and external infrastructure provisions in accordance with the Rezoning Conditions, the Mango Hill Infrastructure Agreement 1999 (MHIA) and agreements made with the State Government in accordance with the DCP. These obligations are summarised as follows:

6.1.1 Roads

Unless already constructed, the Principal Developer must construct the following roads including carriageways, stormwater drainage, verges, bus setdowns, footpaths, bikeways, landscaping, traffic control devices, traffic signals and street lighting as applicable. Any reference to initial construction in this section is a reference to construction approved by Council in accordance with the rezoning conditions, the MHIA and where applicable, the Mango Hill Agreement – Main Roads (MHIA-MR).

- (i) All external roads bounding the site must be constructed at least one lane in each direction by the earlier of:
 - (a) When the Design Peak Hour one way volume on road section Node T to Node AE exceeds 750 vehicles;
 - (b) The date the Council approves a Sector Plan which allows for the development of 85% of the DCP area.
- (ii) Bikeways and pathways required along the road frontages to the Sector and all the above external roads in accordance with the MHIA.(refer to **Figure 7 – Road Layout**)

The construction of the abovementioned infrastructure to the final standard is to be undertaken in accordance with the staging and timing outlined in the MHIA. The initial standard of construction referred to above is to be undertaken to suit the rate of development of the Sector. Where initial construction is not stated, the road is to be constructed to the standard described above to suit the rate of development of the Sector.

6.1.2 Water Supply

- (i) Reticulation systems along all roads is necessary to service all properties in the Sector;
- (ii) Those sections of the mains shown on **Figure 8 – Water Supply Headworks**, necessary to service the anticipated demand in the Sector; and
- (iii) Make contribution towards water headworks and bulk water supply in accordance with the MHIA.

6.1.3 Sewerage

- (i) Trunk gravity main from the existing Council sewerage infrastructure to connect with each lot in the Sector as shown on **Figure 9 – Sewerage Headworks**; and
- (ii) Make contribution towards sewerage headworks supply in accordance with the MHIA.

6.1.4 Park

The requirements for park provision throughout the DCP area are provided for in the MHIA. No area within this Sector will be dedicated as park.

6.1.5 Stormwater

- (i) The Principal Developer must comply with the provisions of the Stormwater Management Plans for Freshwater Creek as approved by Council and construct stormwater management works so far as they relate to this Sector.
- (ii) Stormwater management works so far as they relate to the Sector are to be provided in accordance with the MHIA, Council's Design Manual, the Stormwater Management Plan.
- (iii) In addition, the Principal Developer is to construct stormwater drainage systems and stormwater management systems as required by the MHIA and the Environmental Protection (Water) Policy.

6.1.6 Electricity Supply, Lighting and Communications

- (i) Allow for underground electricity distribution to all properties within the Sector, by Energex or another appropriate supplier of electricity.
- (ii) Arrange for the provision of underground conduits along all road verges within the Sector and adjacent roads to meet the anticipated demands of the DCP area.
- (iii) Provide underground electricity to all properties within the Sector through Energex or another appropriate supplier of electricity and to Council standards.
- (iv) Provide public lighting to all roads, streets, parks and other public areas and facilities within the Sector, constructed to relevant Australian Standards and in accordance with the requirements of Energex or alternative supplier of electricity and Council standards.
- (v) Provide high voltage electricity services to the Sector through Energex or another supplier of electricity and to Council standards.
- (vi) Provide all electricity services and distribution systems as underground services, including conduits along all road verges within the Sector and adjacent roads to meet the anticipated demand of the DCP area.

6.2 INFRASTRUCTURE AFFECTED OR REQUIRED BY DEVELOPMENT OF THE SECTOR

- (i) The development of the Sector may place demands on the following infrastructure:
 - (a) Roads external to the DCP area and the Sector;
 - (b) Water supply infrastructure;
 - (c) Sewerage infrastructure;
 - (d) Stormwater infrastructure;
 - (e) Parks;
 - (f) Community facilities;

- (g) Electricity and gas supply;
 - (h) Communications systems; and
 - (i) State Government Infrastructure.
- (ii) The infrastructure described in clause 6.1 above, together with the obligations of the Principal Developer under infrastructure agreements will mitigate the adverse affects on the above infrastructure.

6.3 HOW THE REQUIRED INFRASTRUCTURE RELATES TO THE INFRASTRUCTURE AGREEMENTS

The infrastructure agreements describe the infrastructure that must be provided by the Principal Developer as part of its obligations to provide infrastructure, as envisaged by Chapter 12 of the DCP. The works described in clause 6.1 of this document are the Principal Developer's obligations under the rezoning conditions and the infrastructure agreements.

7.0 Detailed Infrastructure Program

7.1 ESTIMATED DATE FOR PROVISION OF INFRASTRUCTURE

- (i) The Principal Developer is to provide the infrastructure referred to in clause 6.1 of this document at times to satisfy the requirements of the MHIA. Initial infrastructure works are estimated to be constructed by July 2011.

7.2 INTENDED PROVIDER

The Principal Developer is to provide the infrastructure referred to in Section 6.1 at times to satisfy the requirements of the Rezoning Conditions and the MHIA which provides for the infrastructure to be constructed to meet the rate of development in the Sector.

The following items of State Government infrastructure are also to be provided by the Principal Developer in conjunction with the development of the Sector in accordance with Infrastructure Agreements with the State Government. These include the provision of works to State-Controlled Roads.

7.3 OTHER WORKS DEPENDENT ON INFRASTRUCTURE PROVISION

No other works depend on the provision of the infrastructure specified in Section 6.1.

Council is to use its best endeavours, including its powers of resumption if lawful, to obtain all necessary rights to permit the construction of water and sewerage infrastructure if such infrastructure is constructed on land external to the DCP area over which Council does not have such rights.

7.4 OTHER RELEVANT INFORMATION

7.4.1 Estimated Water and Sewerage Demands

As required by the MHIA, the Principal Developer states as follows:

- (i) For the purpose of assessing water supply capacity, the estimated number of equivalent Tenements for this Sector is 38.13ETs (based on commercial services or uses of the like).

- (i) For the purpose of assessing sewerage capacity, the estimated number of Equivalent Persons for this Sector is 76.25EPs (based on commercial services or uses of the like).

APPENDIX A

FINAL SPECIFICATION

OF LAND USE

FOR THIS SECTOR

**FINAL SPECIFICATION OF LAND USE
(TOWN CENTRE FRAME)
FOR TOWN CENTRE FRAME "O" SECTOR ONE**

Purposes for which premises may be erected or used without the consent of Council (Permitted Development) COLUMN A	Purposes for which premises may be erected or used without the consent of Council subject to conditions (Permitted Development subject to conditions) COLUMN B	Purposes for which premises may be erected or used only with the consent of Council (Permissible Development) COLUMN C	Purposes for which premises may not be erected or used (Prohibited Development) COLUMN D
Self Assessable	Code Assessable	Impact Assessable Development	
Caretaker's residence Local utilities Park	Car park Car wash Catering premises Commercial services Hardware centre Indoor Recreation Office Outdoor Sales Local Utilities Place of Worship Public Utilities Restaurant Retail nursery Sale and information centre Shop <300m ² GFA Shopping Centre <1500m GFA Special Use Technology Industry Tourist attraction Vehicle Hire Depot Vehicle sale yards Veterinary clinic	Any other Use not listed in Column A, B or D	Adult product shop Agriculture Air strip Animal husbandry Aquaculture Bulk garden supplies Camping grounds Caravan park Cattery Cemetery Concrete batching plant Contractor's depot Correctional institution Crematorium Dairy Extractive industry Fuel depot General industry Hazardous industry Heavy vehicle parking Heavy vehicle sales Host farm Junk yard Kennels Lot feeding Motor sport or shooting Piggery Poultry farm Rural industry Shopping centre >1,500m ² GLA Showground Simulated conflict Stable Stock sales yard Transport terminal Transportable home village Turf farming

APPENDIX B

PLANT LIST

**Appendix B: Indicative Plant Schedule -
Town Centre Frame "N" – North Lakes Drive – Sector One**

Botanical Name	Common Name
Trees & Palms	
Acmena smithii	Lilly Pilly
Agathis robusta	Kauri Pine
Allocastrum littoralis	Black She Oak
Allocastrum torulosa	Forest She Oak
Araucaria cunninghamia	Hoop Pine
Archontophoenix cunninghamia	Pickabean Palm
Backhousia citriodora	Lemon Scented Myrtle
Backhousia myrtifolia	Carrol
Banksia integrifolia	Coast Banksia
Barklya syringifolia	Crown of Gold Tree
Brachychiton acerifolium	Flame Tree
Brachychiton rupestre	Bottle Tree
Buckinghamia celsissima	Ivory Curl Flower
Callistemon salignus	Pink Tips
Callistemon viminalis	Weeping Bottlebrush
Callitris columellaris	Bribie Island Pine
Cassia fistula	Golden Shower Tree
Cassia javanica/Cassia siamea	Cassia
Castanospermum australe	Black Bean
Casuarina cunninghamiana	River She Oak
Casuarina glauca	Swamp She Oak
Cupaniopsis anacardioides	Tuckeroo
Elaeocarpus eumundii	
Eucalyptus citriodora	Lemon Scented Gum
Eucalyptus ptychocarpa	Swamp Bloodwood
Eucalyptus curtisii	Plunkett Mallee
Euodia elleryana	Pink Euodia
Ficus Hillii	Hill's Fig
Ficus macrophylla	Moreton Bay Fig
Ficus rubiginosa	Port Jackson Fig
Flindersia australis	Crows Ash
Flindersia pimenteliana	Flindersia
Flindersia schottiana	Bumpy Ash
Grevillea robusta	Silky Oak
Harpullia pendula	Tulipwood
Hymenosporum flavum	Native Frangipani
Jacaranda mimosifolia	Jacaranda
Lagerstroemia indica	Crepe Myrtle
Livistona australis	Livistona
Livistona decipiens	Weeping Cabbage Palm
Livistona nitida	Livistona
Lophostemon confertus	Brush Box
Lophostemon suaveolens	Swamp Box
Melaleuca linariifolia	Snow in Summer
Melaleuca leucadendron	Small Leaved Paperbark
Melaleuca quinquenervia	Broadleaved Paperbark
Metrosideros queenslandicus	Queensland Golden Myrtle
Oreocallis sp. nova (wickhamii)	Tree Waratah
Peltophorum pterocarpus	Yellow poinciana
Phoenix canariensis	Canary Island Palm

**Appendix B: Indicative Plant Schedule -
Town Centre Frame "N" – North Lakes Drive – Sector One**

Botanical Name	Common Name
Trees & Palms	
Podocarpus elatus	Brown Pine
Roystonea regia	Cuban Royal Palm
Syzygium australe	Scrub Cherry
Syzygium franchisee	Giant Water Gum
Syzygium jambos	Rose Apple
Syzygium leuhmanii	Small Leaved Lilly Pilly
Syzygium paniculatum	Dwarf Magenta Cherry
Tristaniopsis laurina	Water Gum
Waterhousia floribunda	Weeping Myrtle
Xanthostemon chrysanthus	Golden Penda
Shrubs	
Baeckea sp. Mt Toza	Dwarf Baeckea
Baeckea virgata	Twiggy Myrtle
Baeckea virgata dwarf	Dwarf Baeckea
Banksia Birthday Candles	Dwarf Banksia
Banksia ericifolia	Heath Banksia
Banksia integrifolia	Coastal Banksia
Banksia robur	Swamp Banksia
Banksia spinulosa var collina	Hairpin Banksia
Callistemon Dawson River	Dawson River
Callistemon Little John	Little John
Callistemon Ned Kelly	Ned Kelly
Callistemon pachyphyllus	Bottlebrush
Cyathea australis	Rough Tree Fern
Gardenia Florida	Double Gardenia
Grevillea "Coconut Ice"	Coconut Ice
Grevillea "Majestic"	Majestic
Grevillea "Robyn Gordon"	Grevillea
Grevillea "Superb"	Superb
Grevillea banksii	Red Silky Oak
Grevillea Honey Gem	Honey Gem
Grevillea Ned Kelly	Ned Kelly
Hibiscus rosa sinensis	Hibiscus
Hovea acutifolia	Pointed Leaf Hovea
Leptospermum flavescens	Tantoon Tea Tree
Leptospermum petersonii	Lemon Scented Tea Tree
Leptospermum Pink Cascade	Pink Cascade
Melaleuca linariifolia Snowflake	Dwarf Tea Tree
Murraya paniculata	Orange Jessamine
Pittosporum revolutum	Brisbane Laurel
Pittosporum undulatum	Mock Orange
Syzygium Blaze	Dwarf Lilly Pilly
Syzygium Elite	Compact Lilly Pilly
Syzygium Tiny Trev	Dwarf Lilly Pilly
Tibouchina jules	Tibouchina
Westringea fruticosa	Wynyabbie Gem

**Appendix B: Indicative Plant Schedule -
Town Centre Frame "O" – North Lakes Drive – Sector One**

Botanical Name	Common Name
Groundcovers	
Agapanthus africanus	Lily of the Nile
Agapanthus orientalis	Lily of the Nile
Agapanthus Peter Pan	Dwarf Agapanthus
Anigozanthos hybrids	Kangaroo Paws
Blechnum cartilagineum	Fern
Cissus rhombifolium	Grape Ivy
Cissus Ellen Danica	Grape Ivy
Crinum pendunculatum	River Lily
Dianella revoluta	Flax Lily
Dietes bicolor	Japanese Iris
Dietes grandiflora	Japanese Iris
Evolvulus pilosus	Blue Sapphire
Gardenia radicans	Dwarf Gardenia
Grevillea Bronze Rambler	Bronze Rambler
Grevillea Royal Mantle	Prostrate Grevillea
Hardenbergia violacea	Purple Coral Pea
Hardenbergia violacea Bushy Blue	Bushy Blue
Helichrysum ramosissimum	Yellow Buttons
Hemerocallis species	Day Lily
Hibbertia dentata	Toothed Guinea Flower
Hibbertia scandens	Snake Vine
Liriope "Evergreen Giant"	Liriope
Lomandra hystrix	Creek Mat rush
Lomandra longifolia	Mat Rush
Lomandra multiflora	Long Leaved Mat Rush
Myoporum ellipticum	Creeping Boobialla
Myoporum parvifolium	Myoporum
Pittosporum Miss Muffet	Dwarf Pittosporum
Pittosporum tobira	Miss Muffet
Viola hederacae	Native Violet
Zierra Carpet Star	Carpet Star
Grasses	
Cynodon dactylon	Green Couch
Danthonia induta	Wallaby Grass
Digitaria didactyla	Blue Couch
Greenlees Park	Hybrid Couch
Poa australis	Native Poa
Vines	
Jasminum polyanthum	Jasmine
Pandorea pandorana	Wonga Wonga Vine
Pandorea jasminoides	Bower of Beauty
Trachelospermum jasminoides	Variegated Star Jasmine
Trachelospermum jasminoides	Star Jasmine

APPENDIX C

Bicycle Parking Requirements

BICYCLE PARKING REQUIREMENTS (TOWN CENTRE FRAME 'O' PRECINCT) FOR TOWN CENTRE FRAME 'O' SECTOR ONE

Land use	Employee Bicycle Parking spaces	Class
Car park	1 space per 750m ² GFA	1
Car Wash	1 space per 750m ² GFA	2
Catering premises	1 space per 750m ² GFA	
Restaurant	1 space per 100m ² GFA (including outdoor dining area)	2
Service station	1 space per 750m ² GFA	2
Shop < 300m ² GFA	1 space per 300m ² GFA	2
Special use	1 space per 750m ² GFA	2
Tourist facility	1 space per 750m ² GFA	2
Veterinary clinic	1 space per 300m ² GFA	2

Notes:-

1. GFA – Gross floor area, as defined in the DCP;
2. The provision of bicycle spaces recommended in the table may be staged initially depending on the demand for use, however space should be set aside to allow 100% provision in the event that the full demand for bicycle parking is realised.

Types of Parking Devices

Class	Security Level	Description	Main User Type
1	High	Fully enclosed individual lockers	Bike and ride commuters at railway and bus stations.
2	Medium	Located compounds fitted with Class 3 facilities. Communal access using duplicate keys or electronic swipe cards	Regular employees, students, regular bike and ride commuters.
3	Low	Facilities to which the bicycle frame and wheels can be locked	Shoppers, visitors to public offices, places of employment where there is security supervision of the parking facilities.

APPENDIX D

TOWN CENTRE FRAME SIGNAGE GUIDELINES



NORTH LAKES

NORTH LAKES TOWN CENTRE FRAME SIGNAGE GUIDELINES

1.0 OBJECTIVES

The objectives of the signage standards for North Lakes are:

- (i) To implement design standards consistent with the existing and future character of North Lakes
- (ii) To ensure that signs and advertisements complement the attractiveness, safety, legibility and amenity of the North Lakes environment, both day and night
- (iii) To support the role of signs and advertising as an important factor in the marketing of North Lakes and in identifying the commercial character in areas of the development.

2.0 DEFINITIONS

Animated Signage:

An animated sign is an advertisement with a changing display, such as flashing or chasing bulbs, or any other non-static illuminated displays.

Third Party Advertising:

A "third party" advertising sign is an advertisement for a business not conducted on the land on which the sign is located, or a commodity not available on that land, and includes an advertisement for a particular brand of product sold or distributed from the premises. However, an advertising sign which incorporates the North Lakes logo as an integral element of the signage, or a sign which includes only a generic reference to the type of product available on the land is not a "third party" advertising sign in terms of the inclusion of the North Lakes logo or the generic product reference.

On- Site Business Advertising:

An on-site business advertising sign is an advertising sign which is limited in its content to the name of a business premises and the name and services offered by the occupants of the business premises. An on-site business advertising sign may also incorporate the North Lakes logo as an integral element of the signage.

Artworks/Murals:

Artwork and murals are architectural graphics and other artworks which do not contain any implied or direct reference to a business undertaking or service or commodity available from a business undertaking. However, artworks and murals may incorporate the North Lakes logo as a supporting or an ancillary element.

3.0 SIGNAGE GUIDELINES

Except in the case of road signs, the following guidelines will be applied to all advertising signage erected in the North Lakes Town Centre Frame. The following guidelines are to be read in association with the guidelines contained in Section 7.9.1 of this Sector Plan.

These guidelines are intended to apply for individual signs, but where they form part of a coordinated signage plan, they can be varied.

3.1. Scale and Location of Signs on Buildings

The scale of the sign shall be compatible with the building and building elements on which it is affixed and to which it is in proximity, as well as nearby buildings, streets and other existing signs. Consideration shall be given to the sign's relationship to the overall appearance of the development as well as surrounding development.

The number and area of signs, if specified, are intended to be maximum standards.

3.2. Principal Developer Signs

Within road reservations and on land in ownership of the Council or the principal developer, signage content is limited to the message requirements of the principal developer and traffic control. Generally content of signs within these areas will be restricted to directional information for identifying locations, buildings, services and events. Commercial business names or logos will generally not be permitted except for sponsorships on temporary event signs.

3.3. Traffic Safety

A sign must not obstruct pedestrians' views of traffic or vehicle drivers' views of pedestrians, other traffic or the road ahead. A sign must not create possible confusion for drivers at critical locations such as intersections, traffic signals, or merging and weaving situations eg. red and green lit signage near traffic intersections.

3.4. Installation Fixings

No support, fixing, suspension or other systems required for the installation of a sign shall be exposed, unless designed as an integral feature of the sign. Conduits, wiring, switches etc shall be discreetly placed out of general view.

3.5. Animated Signs

Animated signs, where parts or all of the sign components move, may be acceptable in non-residential environments where no significant adverse impacts are likely to adjacent or nearby sensitive land uses.

3.6. Clutter

The visual amenity of the local area and the effectiveness of the message on the sign will be enhanced by reducing signage clutter. Proposed signs shall be assessed in the context of the number, type, size and location of existing signs on the site and surrounds.

3.7. Illumination

The luminance of an externally illuminated advertisement in the Town Centre Core (measured in candelas per square metre) is not to exceed 500 cd/m².

The luminance level of an advertisement may exceed this level where it can be shown that the increase in luminance level is unlikely to contribute to a traffic hazard or cause an inappropriate loss of amenity.

The external illumination of signs is to be carried out in such a way as to minimise the spill effects beyond the target sign. An illuminated sign must be designed to make the best possible use of the energy efficient equipment and light sources available.

At street level sign illumination is to be consistent with the general level of lighting so as to eliminate shadows and promote the safety of adjoining public areas.

The intensity of lighting and hours of illumination must not unreasonably impact on any residential properties or traffic operations.

3.8. Environmental Controls

A sign must not be nailed or similarly fixed to a tree. Every sign shall be maintained and kept in good repair.

3.9. Performance Controls

Unless otherwise approved under the coordinated signage plan, a proposed sign must meet the performance criteria outlined in the following section. The acceptable standards associated with each type of sign are provided as examples and should not be seen as precluding other solutions. However, where alternative solutions are proposed, the onus will be on the proponent to demonstrate that the relevant performance criteria are met.

SIGNS PERFORMANCE CRITERIA



Signs shall:

- (i) not create a hazard to traffic or pedestrians**
- (ii) be of character and design standard consistent with the objectives and controls for this sector plan**
- (iii) complement the streetscape and amenity of the locality by virtue of their size, location, illumination, utilisation of complementary shapes, forms, colours, durable quality materials and design concepts**
- (iv) if affixed to a building, complement the architectural style of the building by virtue of their size, location, illumination, utilisation of complementary shapes, forms, colours, durable quality materials and design concepts; and**
- (v) not unnecessarily repeat or duplicate similar signs.**

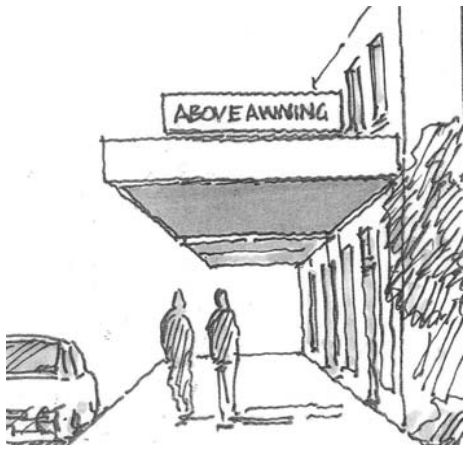

4.0 TYPES OF SIGNS

The following schedule sets out maximum criteria for various types of signs. Such signs may be permitted subject to the overall performance standards being met.

- (i) Above Awning Sign
- (ii) Awning / Fascia Sign
- (iii) Blind Sign
- (iv) Business Plate
- (v) Canopy Sign
- (vi) Created Awning Sign
- (vii) Flag Pole Sign
- (viii) Footway Sign
- (ix) Ground Sign
- (x) Hamper Sign
- (xi) Highrise Building Sign
- (xii) Lantern Sign
- (xiii) Pole Sign
- (xiv) Projecting Flag Sign
- (xv) Projecting Sign
- (xvi) Stallboard Sign
- (xvii) Under Awning Sign
- (xviii) Vertical Banner Building Sign
- (xix) Vertical Banner Freestanding Sign
- (xx) Wall Sign
- (xxi) Window Sign
- (xxii) Pylon/Column Sign
- (xxiii) Large Pylon Sign

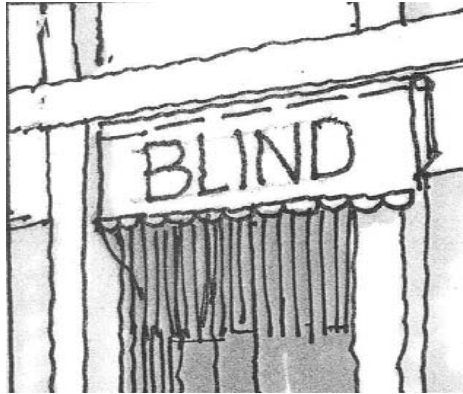

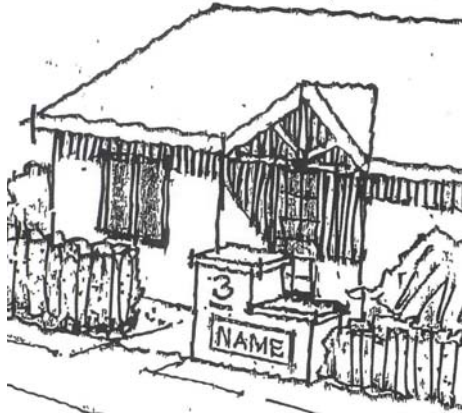
TYPE OF SIGN	EXAMPLE OF TYPE OF SIGN	ACCEPTABLE STANDARD FOR SPECIFIC SIGN STYLE	
<p>ABOVE AWNING SIGN An Above Awning Sign is an advertisement above an awning, verandah roof or the like.</p>		<p>Maximum size</p> <p>Maximum height above awning</p> <p>Extent</p> <p>Other requirements</p>	<p>Length - 2.7 metres Height - 0.6 metres Width - 0.3 metres</p> <p>1.0 metre</p> <p>Not to project beyond the edges of the awning</p> <p>No unsightly supports or rear view of sign. Any unsightly supports required for structural reasons are to be set back behind edges of sign</p>
<p>AWNING/FASCIA SIGN An Awning/Fascia Sign is an advertisement painted or otherwise affixed to the fascia of a building, an awning, verandah or return end of an awning.</p>		<p>Maximum extent</p> <p>Maximum height</p> <p>Maximum thickness</p>	<p>Not projecting above or below the fascia</p> <p>0.6 metre</p> <p>0.1 metre out from fascia</p>

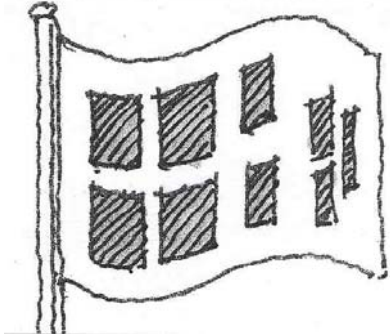

TYPE OF SIGN	EXAMPLE OF TYPE OF SIGN	ACCEPTABLE STANDARD FOR SPECIFIC SIGN STYLE	
<p>BLIND SIGN A Blind Sign is an advertisement painted on or otherwise affixed to solid or flexible material suspended from the edge of an awning, verandah or wall.</p>		<p>Minimum clearance between the lower most point of the sign and the footway Maximum number</p>	<p>2.4 metres 1 per tenancy frontage</p>

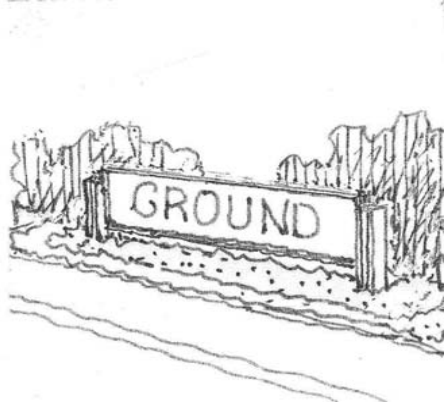
TYPE OF SIGN	EXAMPLE OF TYPE OF SIGN	ACCEPTABLE STANDARD FOR SPECIFIC SIGN STYLE	
<p>BUSINESS PLATE A Business Plate is a small advertisement identifying the name and/or trade, business or calling of the occupant or business premises. A Business Plate may be painted or affixed to a wall.</p>		<p>Maximum surface area of sign residence in a residential area Maximum surface area per business occupant of premises in commercial and mixed use areas</p>	<p>0.3 square metres 0.3 square metres</p>
<p>CANOPY SIGN A Canopy Sign is an advertisement, painted or otherwise affixed, to a canopy, whether the canopy is constructed from flexible or solid material.</p>		<p>Minimum clearance between the lower most part of the sign and the footway Maximum number</p>	<p>2.4 metres 1 per tenancy frontage</p>



TYPE OF SIGN	EXAMPLE OF TYPE OF SIGN	ACCEPTABLE STANDARD FOR SPECIFIC SIGN STYLE	
<p>CREATED AWNING LINE SIGN A Created Awning Line Sign is an advertisement attached to and extending beyond a fascia of an awning or the like.</p>		<p>Extent</p> <p>Maximum area</p> <p>Minimum clearance</p>	<p>Not more than 0.6 metre above the fascia to which it is attached</p> <p>The created area is not to exceed 25% of the fascia</p> <p>2.4 metres to the footpath pavement</p>
<p>FLAG POLE SIGN A Flag Pole Sign is a fabric sign hung from a pole.</p>		<p>Maximum surface area</p> <p>Maximum height above ground</p>	<p>3.0 square metres</p> <p>6.5 metres if planted in the ground</p>

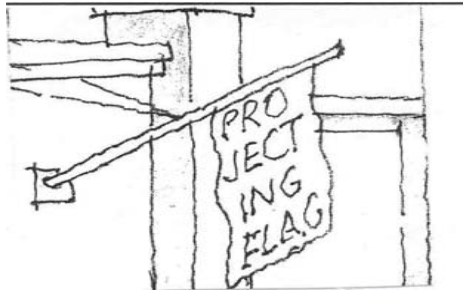
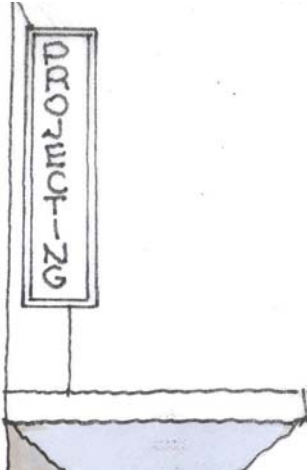

TYPE OF SIGN	EXAMPLE OF TYPE OF SIGN	ACCEPTABLE STANDARD FOR SPECIFIC SIGN STYLE	
<p>FOOTWAY SIGN A Footway Sign is a portable, freestanding advertisement, normally supported by an 'A' or inverted 'T' frame, and typically displayed on a footway.</p>		<p>Maximum size</p> <p>Maximum number Location</p> <p>Other requirements</p>	<p>Height - 1.0 metre Width - 0.6 metre Depth - 0.6 metre</p> <p>1 per tenancy</p> <p>A Footway Sign on a footway is to be positioned near the kerb (but not closer than 0.25 metre) so as to leave clear passage for pedestrians along the footway, particularly the visually disadvantaged who rely on clear passage along the frontage of shops.</p> <p>No footway sign is to be positioned so as to obstruct, clutter or detract from street landscaping, furniture or artwork</p> <p>A Footway Sign not to be located on a public road.</p> <p>A Footway Sign is not to have moving, rotating or animated parts, such as a spinner sign. A Footway Sign is to be displayed only during trading hours and is not to be used for the display of merchandise</p>
<p>GROUND SIGN A Ground Sign is a monolithic sign which, in effect, sits on or rises out of the ground.</p>		<p>Setting</p> <p>Maximum height Maximum surface area Maximum setback from side boundary Maximum number</p>	<p>Erected within a landscaped environment.</p> <p>Not erected to expose an unsightly back view of the sign.</p> <p>When in a residential area, only permitted where used in a name of a multi-unit development site</p> <p>1.8 metres</p> <p>10 square metres</p> <p>3 metres</p> <p>One per frontage for frontages up to 100 metres</p> <p>For frontages over 100 metres, spacing of signs to be no less than 60 metres</p>

TYPE OF SIGN	EXAMPLE OF TYPE OF SIGN	ACCEPTABLE STANDARD FOR SPECIFIC SIGN STYLE	
<p>HAMPER SIGN A Hamper Sign is an advertisement, painted or otherwise affixed, between a door head and an awning, or their equivalent levels.</p>		<p>Maximum thickness Maximum Extent</p>	<p>0.3 metre from the face of the wall The size and form are to be compatible with the building on which they are located.</p>
<p>HIGH RISE BUILDING SIGN A High Rise Building Sign is an advertisement naming or identifying a high rise building by the use of a logo or the like.</p>		<p>Maximum extent Maximum number Other requirements</p>	<p>Contained within the actual or created outline of a building or appears as if it was part of the original building if part of a structure creating a changed building outline One per building frontage A High Rise Building Sign is not to contain third party advertising</p>

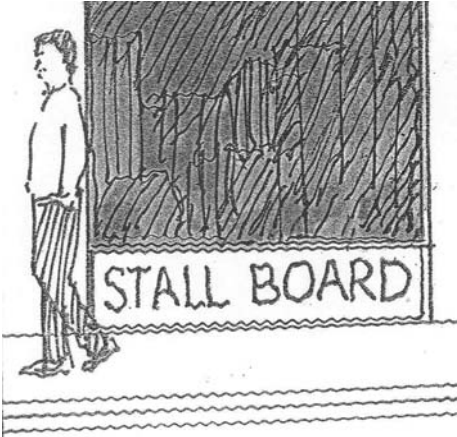
TYPE OF SIGN	EXAMPLE OF TYPE OF SIGN	ACCEPTABLE STANDARD FOR SPECIFIC SIGN STYLE	
<p>LANTERN SIGN A Lantern Sign is a translucent lighting fixture displaying the name and/or trade, business or calling of the occupant.</p>		<p>Maximum number for a Home Occupation or Business</p> <p>Maximum edge dimension of lantern</p> <p>Maximum height</p> <p>Maximum illumination</p>	<p>One</p> <p>0.5 metre (ie to fit into a Cube of 0.5 x 0.5 x 0.5 metres)</p> <p>2 metres</p> <p>Not greater than a standard 100 watt incandescent bulb</p>
<p>POLE SIGN A Pole Sign is a freestanding sign mounted on one or more vertical supports which has a smaller surface area and a lower height than a Pylon/Column sign.</p>		<p>Maximum number</p> <p>Aspect</p> <p>Maximum surface area</p> <p>Maximum height above ground</p> <p>Minimum setback from side boundary</p> <p>Setting</p>	<p>One two-sided pole sign per allotment street frontage</p> <p>Not erected to expose an unsightly back view of the sign</p> <p>2.4m² per side, except along Anzac Avenue where it may be increased to 8m² per side for a maximum of two sides.</p> <p>4.5 metres, except along Anzac Avenue, where the maximum height may be 10 metres and along Discovery Drive where the maximum height may be 6 metres.</p> <p>3 metres</p> <p>Erected within a landscaped environment</p>

TYPE OF SIGN	EXAMPLE OF TYPE OF SIGN	ACCEPTABLE STANDARD FOR SPECIFIC SIGN STYLE	
<p>PROJECTING FLAG SIGN A Projecting Flag Sign is a non-illuminated, wall-mounted corporate flag.</p>		<p>Maximum size Maximum number Minimum spacing Minimum clearance</p>	<p>0.3 square metre per face 4 per site 2 metres 2.4 metres to the footpath pavement.</p>
<p>PROJECTING SIGN A Projecting Sign is a double-faced sign projecting at right angles to a wall and fixed to the wall. A Projecting Sign is not an Under Awning Sign.</p>		<p>Minimum clearance between the lowermost point of the sign and the footway Maximum number Orientation Extent Maximum size</p>	<p>2.4 metres One per building frontage Vertical Not projected above the height of the wall to which it is attached Height - 3.0 metres Width - 0.75 metre</p>

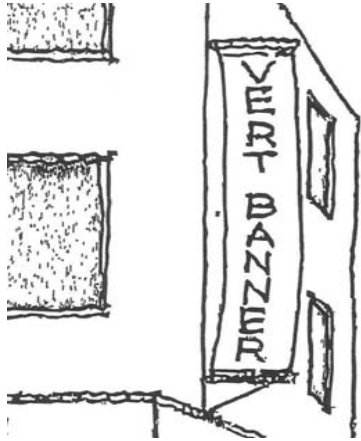
TYPE OF SIGN	EXAMPLE OF TYPE OF SIGN	ACCEPTABLE STANDARD FOR SPECIFIC SIGN STYLE	
<p>STALLBOARD SIGN A Stallboard Sign is an advertisement, painted or otherwise affixed, at the base of a shopfront, normally below a shop window</p>		<p>Fixing</p> <p>Maximum Extent</p>	<p>Fitted flush</p> <p>The size and form are to be compatible with the building on which they are located.</p>
<p>UNDER AWNING SIGN An Under Awning Sign is an advertisement suspended under an awning or verandah.</p>		<p>Orientation</p> <p>Minimum clearance between the lowermost point of the sign and footway</p> <p>Extent</p> <p>Location</p> <p>Minimum distance between under awning signs</p> <p>Maximum dimensions</p> <p>Minimum setback from side boundary</p>	<p>At right angles to the building frontage</p> <p>2.4 metres</p> <p>Not to project beyond the awning or verandah</p> <p>Central to each shop or tenancy or shopping arcade entrance</p> <p>3.0 metres</p> <p>Length - 2.7 metres or not greater than 75% of the width of the awning or verandah which ever is lesser</p> <p>Height - 0.6 metres</p> <p>Width - 0.3 metres</p> <p>1.5 metres</p>

TYPE OF SIGN	EXAMPLE OF TYPE OF SIGN	ACCEPTABLE STANDARD FOR SPECIFIC SIGN STYLE	
<p>VERTICAL BANNER BUILDING SIGN A Vertical Banner Building Sign is an advertisement of non-rigid material normally fixed at the top and bottom to brackets projecting from a building.</p>		<p>Maximum height</p> <p>Maximum width</p> <p>Minimum clearance between lowermost point of the sign and the footway</p> <p>Maximum area</p> <p>Minimum spacing between signs</p> <p>Minimum setback from side or rear boundary</p>	<p>Not to project above the height of the adjacent part of the building to which it is fixed and not to exceed 5 metres above ground level</p> <p>0.75 metre</p> <p>2.4 metres</p> <p>2.4 square metres</p> <p>6.0 metres</p> <p>3.0 metres</p>
<p>VERTICAL BANNER FREESTANDING SIGN A Vertical Banner Freestanding Sign is an advertisement of non-rigid material normally supported at two or more locations from brackets extending from a freestanding pole.</p>		<p>Maximum height (above ground level to top most support)</p> <p>Maximum width</p> <p>Minimum clearance between lowermost point of the sign and the footway</p> <p>Minimum spacing between signs</p> <p>Minimum setback from side boundary</p> <p>Maximum surface area</p>	<p>5.0 metres</p> <p>0.75 metre</p> <p>2.4 metres</p> <p>6.0 metres</p> <p>3.0 metres</p> <p>2.4 square metres</p>

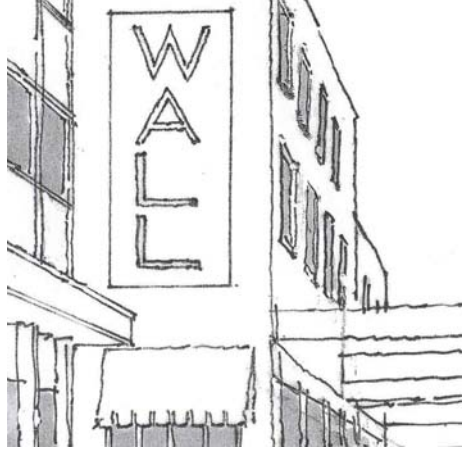
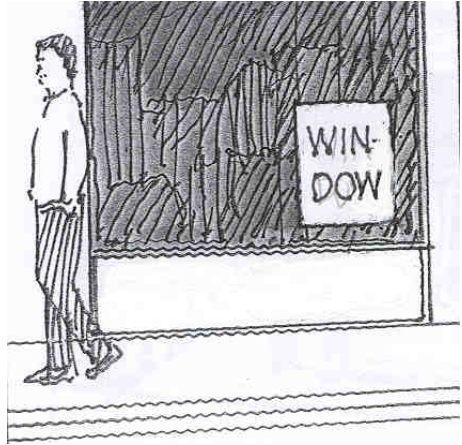
TYPE OF SIGN	EXAMPLE OF TYPE OF SIGN	ACCEPTABLE STANDARD FOR SPECIFIC SIGN STYLE	
<p>WALL SIGN A Wall Sign is an advertisement, painted or otherwise affixed, flat to a wall.</p>		<p>Maximum thickness (or projection from wall) Maximum number Maximum surface area Location</p>	<p>0.3 metre One per tenancy 20% of wall space or 6 m², whichever is the lesser Ground floor level and first floor level and not to project beyond the edge of the wall.</p>
<p>WINDOW SIGN A Window Sign is an advertisement, painted or otherwise affixed, to the glass of a display window.</p>		<p>Maximum surface area of sign</p>	<p>25% of the area of the glass panel or panels on which it is displayed</p>

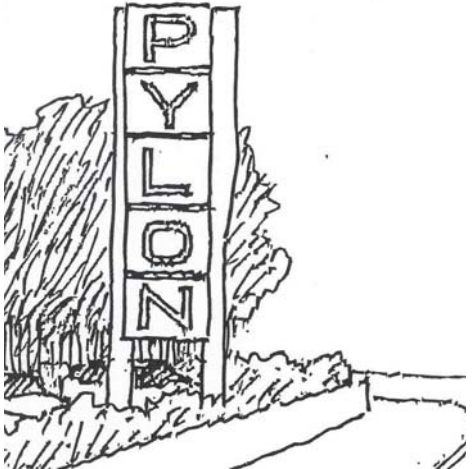
TYPE OF SIGN	EXAMPLE OF TYPE OF SIGN	ACCEPTABLE STANDARD FOR SPECIFIC SIGN STYLE	
<p>SMALL PYLON SIGN Small Pylon Signs shall be considered on merit and streetscape context in consideration of architectural and landscaping themes and overall site signage.</p>		<p>Aspect</p> <p>Maximum surface area of sign</p> <p>Maximum height above the ground</p> <p>Setting</p> <p>Maximum number</p> <p>Minimum setback from side boundary</p>	<p>Not be erected to expose an unsightly back view of the sign</p> <p>5 square metres per side, for a maximum of two sides.</p> <p>The maximum height is to be 3.0 metres.</p> <p>Erected within a landscaped environment</p> <p>No Small Pylon Sign shall be erected on a site along which are located Pylon/Column signs unless the frontage exceeds 100 metres in which case such signs are to be no closer than 60 metres.</p> <p>Location and maximum number as per Sector Plan</p> <p>3.0 metres</p>

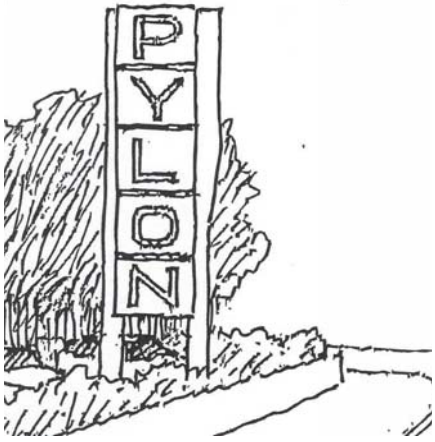
TYPE OF SIGN	EXAMPLE OF TYPE OF SIGN	ACCEPTABLE STANDARD FOR SPECIFIC SIGN STYLE	
<p>PYLON/COLUMN SIGN A Pylon/Column Sign is a large display surface with its height being greater than its width. It may be erected on the ground or mounted on one or more vertical supports.</p>		<p>Aspect</p> <p>Maximum surface area of sign</p> <p>Maximum height above the ground</p> <p>Setting Maximum number</p> <p>Minimum setback from side boundary</p>	<p>Not be erected to expose an unsightly back view of the sign</p> <ul style="list-style-type: none"> • 20 square metres per side, for a maximum of two sides along Anzac Avenue. • 15 square metres per side, for a maximum of two sides elsewhere in the Town Centre Frame. • The maximum height is to be 5.0 metres, or the height of a building in close proximity, but is not to exceed 6.0 metres. <p>Erected within a landscaped environment No Pylon/Column Sign shall be erected on a site along which another Pylon Sign is located unless the frontage exceeds 100 metres in which case such signs are to be no closer than 60 metres. Location and maximum number as per Sector Plan 3.0 metres</p>

APPENDIX E

PROPOSED METES AND BOUNDS DESCRIPTION OF THE SECTOR

METES & BOUNDS
TOWN CENTRE FRAME 'O' PRECINCT
TOWN CENTRE FRAME 'O' SECTOR FOUR

FROM THE POINT OF COMMENCEMENT BEING ON AMG COORDINATES
EASTING -500988.877 METRES, NORTHING -6986825.526 METRES, THENCE
IN A NORTH WESTERLY DIRECTION AT A BEARING OF 309°52'
FOR A DISTANCE OF 140.769 METRES (MORE OR LESS), THENCE
IN A NORTH EASTERLY DIRECTION AT A BEARING OF 39°52'
FOR A DISTANCE OF 5 METRES (MORE OR LESS), THENCE
IN A NORTH WESTERLY DIRECTION AT A BEARING OF 309°52'
FOR A DISTANCE OF 4.8 METRES (MORE OR LESS), THENCE
IN A SOUTH WESTERLY DIRECTION AT A BEARING OF 219°52'
FOR A DISTANCE OF 5 METRES (MORE OR LESS), THENCE
IN A NORTH WESTERLY DIRECTION AT A BEARING OF 333°0'
FOR A DISTANCE OF 4.847 METRES (MORE OR LESS), THENCE
IN A NORTHERLY DIRECTION AT A BEARING OF 3°0'
FOR A DISTANCE OF 32.835 METRES (MORE OR LESS), THENCE
IN A NORTH EASTERLY DIRECTION AT A BEARING OF 40°41'10"
FOR A DISTANCE OF 151.814 METRES (MORE OR LESS), THENCE
IN A SOUTH EASTERLY DIRECTION AT A BEARING OF 128°56'50"
FOR A DISTANCE OF 124.481 METRES (MORE OR LESS), THENCE
IN A SOUTH EASTERLY DIRECTION AT A BEARING OF 128°06'
FOR A DISTANCE OF 17.037 METRES (MORE OR LESS), THENCE
IN A SOUTH EASTERLY DIRECTION AT A BEARING OF 125°51'
FOR A DISTANCE OF 3.7 METRES (MORE OR LESS), THENCE

IN A SOUTH WESTERLY DIRECTION AT A BEARING OF 216°25'20"
FOR A DISTANCE OF 30.281 METRES (MORE OR LESS), THENCE
IN A SOUTH EASTERLY DIRECTION AT A BEARING OF 124°03'30"
FOR A DISTANCE OF 17.001 METRES (MORE OR LESS), THENCE
IN A SOUTHERLY DIRECTION AT A BEARING OF 177°22'
FOR A DISTANCE OF 8.22 METRES (MORE OR LESS), THENCE
IN A SOUTH WESTERLY DIRECTION AT A BEARING OF 220°36'30"
FOR A DISTANCE OF 148.2 METRES (MORE OR LESS),
TO THE POINT OF COMMENCEMENT AND CONTAINING AN AREA OF
2.98 HECTARES (MORE OR LESS).

We, RPS (Brisbane) Pty Ltd A.C.N. 010 370 448 hereby certify that the Metes and Bounds description contained herein has been prepared by the company and the AMG connection used for the commencement point has been determined by field survey.

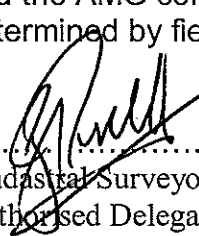
.....
Cadastral Surveyor/
Authorised Delegate

29-6-11
.....
Date