

MANGO HILL INFRASTRUCTURE DEVELOPMENT CONTROL PLAN

Sector Plan No. 032-2000

for

**Town Centre Frame “H” Sector Two
Corner Memorial Drive and Discovery Drive**

Town Centre Frame “H” Precinct

North Lakes Development

(As approved by Moreton Bay Regional Council on 21 October 2008)

A.1 Contents

1.0 Introduction and Statutory Context.....	4
2.0 Land Use Rights	5
3.0 Development Requirements & Guidelines.....	5
3.1 Introduction.....	5
3.2 Development Concept	5
3.3 Development Requirements.....	7
3.4 Standard Design & Siting Measures.....	8
3.5 Specific Medium Density Apartment Design and Siting Guidelines	
3.6 Landscaping / Townscaping	19
3.7 Carparking, Service Areas & Loading Docks	22
3.8 Signage	24
4.0 Environmental Management.....	25
5.0 Subdivision Requirements.....	25
6.0 Infrastructure	26
6.1 Infrastructure To Be Provided	26
6.2 Infrastructure Affected Or Required By Development Of The Sector.....	28
6.3 How The Required Infrastructure Relates To The Infrastructure Agreements	28
7.0 Detailed Infrastructure Program.....	28
7.1 Estimated Date For Provision Of Infrastructure	28
7.2 Intended Provider.....	28
7.3 Other Works Dependent On Infrastructure Provision	28
7.4 Other Relevant Information.....	29

Contents

FIGURES:

Figure	Reference	Date
1. Planning Context	TCFH-sectorfig 1	September 2008
2. Cadastral Boundaries	TCFH -sectorfig 2	September 2008
3. Precinct Plan Map	TCFH -sectorfig 3	September 2008
4. Sector Plan Map	TCFH -sectorfig 4	September 2008
5. Sector Landscape Plan	TCFH -sectorfig 5	September 2008
6. Indicative Plan of Subdivision	TCFH -sectorfig 6	September 2008
7. Road Layout	TCFH -sectorfig 7	September 2008
8. Water Supply Headworks	TCFH -sectorfig 8	September 2008
9. Sewerage Headworks	TCFH -sectorfig 9	September 2008

APPENDICES:

- A. Final Specification of Land Use for the Sector
- B. Plant List
- C. Bicycle Parking Requirements
- D. Town Centre Signage Guidelines
- E. Proposed Metes and Bounds Description

1.0 Introduction and Statutory Context

- 1.1 The Mango Hill Infrastructure Development Control Plan (DCP) provides a process for development of land in the DCP area and for the creation of a Sector within a Precinct and the preparation by the Principal Developer of a Sector Plan in accordance with the relevant provisions of the DCP.
- 1.2 This document constitutes the Sector Plan for the **Town Centre Frame “H” Sector Two – Corner Memorial Drive and Discovery Drive** (Sector Plan).
- 1.3 The location of the Sector within the DCP area is shown on *Figure 1 – Planning Context*. As illustrated on *Figure 2 – Cadastral Boundaries*, the Sector is bounded by:
- (i) Memorial Drive along the northern boundary;
 - (ii) Major Community Facilities “A” Precinct 009- North Lakes State School over Discovery Drive to the east;
 - (iii) The balance of Town Centre Frame “C” Precinct – Discovery Drive (Precinct Plan 019) to the south; and
 - (iv) The balance of the Town Centre Frame “H” Precinct (Precinct Plan 032) to the south and south west.
- 1.4 The location of the Sector within the Precinct Plan area is shown on *Figure 3 – Precinct Plan Map*.
- 1.5 This Sector Plan is the code of development for the land in the Sector. In the event that this Sector Plan does not provide development requirements, then the Planning Scheme provisions relevant to the particular form of development apply.
- 1.6 The DCP, approved Precinct Plans and approved Sector Plans are to be read in conjunction with the planning scheme and Council’s local laws, policies and codes and to the extent the DCP, Precinct Plans and Sector Plans do not modify provisions of the Council’s planning scheme, local laws, policies and codes they will apply to the DCP area.
- 1.7 To the extent the provision of Council’s planning scheme, local laws, policies or codes are modified by the DCP, Precinct Plans or Sector Plans, then the provisions of the DCP, the Precinct Plans or Sector Plans will prevail.
- 1.8 Development in the Sector must comply with the provisions of the Sector Plan.

2.0 Land Use Rights

The final specification of land use rights for land in this Sector is contained in *Appendix A – Final Specification of Land Use for the Sector*.

3.0 Development Requirements & Guidelines

3.1 INTRODUCTION

Clause 2.4.2 of the DCP indicates that a Sector Plan must specify the requirements for land use, development and car parking for land in the Sector. Guidelines must also be specified for design and siting, landscaping and signage within the Sector.

3.2 DEVELOPMENT CONCEPT

The Sector is located at the intersection of a major thoroughfares being Memorial Drive and Discovery Drive. The Sector also forms an entry point to the North Lakes Town Centre when approached from the north and is therefore located in a visually prominent part of the DCP area. From an urban design and town planning perspective, the Sector should create a transition between the town centre frame area and the residential environment to the north of the Sector, assist legibility and strengthen the urban form of the town centre.

The development concept for this Sector is for low-medium rise mixed use: small scale retail (ground floor only), commercial and residential development that requires accessibility, without requiring visibility from Anzac Avenue and the Bruce Highway. As such, it is expected that areas adjacent to Memorial Drive for residential with ground floor shops and offices as a transition into the Town Centre Frame.

Development with frontage to Memorial and Discovery Drive are to have a high level of contemporary architectural design and are to address the street in order to contribute to its 'boulevard' character. Memorial and Discovery Drive are envisaged as a wide streetscape with dense landscaping along the verges and median strips. On-site landscaping should be integrated with the design of the building to allow visual exposure of the buildings from the road, but still provide screening or relief to building walls and car parking areas.

Small scale retail (shops less than 300m²) are permitted. No single tenancy shall exceed 300m² on lots where Shopping Centre (Lots 45, 46, 49 and 50 and 47 and 48) is permitted. No more than 1500m² of Shopping Centre uses are permitted on Lots 45, 46, 49 and 50 collectively and are of 1500m² on Lots 47 and 48 collectively) No more than one shop is permitted on Lot 51.

Development within the Sector is to address both the Discovery Drive and Memorial Drive street frontages, whilst maintaining an attractive presentation to car parking areas and pedestrian thoroughfares. Any building or part of a building, located nearest to the Discovery Drive/Memorial Drive corner truncation may incorporate a reduced frontage setback distance, present an alternative façade to each street frontage and have a high quality streetscape character which may incorporate generous footpaths,

awnings and display windows.

To strengthen the urban form and provide visual focus points for the Sector, development within the Sector is encouraged to incorporate a corner feature treatment. Treatments may include an outward orientated building design to both road frontages, awnings and display windows, where appropriate. The public entry to the building may form a highlight of this corner.

While limited car parking is permitted between the road alignment and any building, further car parking shall generally be located behind the building or otherwise appropriately landscaped to minimise the negative visual impact of the development from the street. Pedestrian safety is to be a priority with the use of paving treatments to define and encourage the use of pedestrian movement areas. Where possible, left in/left out access arrangements are proposed along Discovery Drive to reinforce the primary role of the thoroughfare.

The residential component is to be developed as a high quality, mixed community forming an integral part of the North Lakes development. It will comprise medium density apartments providing maximum density of 80 dwellings per hectare.

Development in the Sector should:

- (i) provide for the future commercial / small scale retail and medium – high density residential needs within North Lakes and the surrounding region;
- (ii) be consistent with community expectations of the facilities and services likely to be found in the town centre;
- (iii) ensure connectivity, integration and strong functional and architectural relationships with the commercial developments within the Sector, Precinct and the balance of the Town Centre;
- (iv) ensure that car parking areas in the Sector are enhanced by landscaped vehicular and pedestrian links. Potential conflicts are minimal in front of any points between vehicular and pedestrian movements are to be minimised through considerate design;
- (v) continue the ‘boulevard’ streetscape and landscaping theme along Discovery Drive and Memorial Drive, in order to maintain an attractive entry to the residential community to the north of the Sector;
- (vi) where possible, provide shared vehicular access along Discovery Drive, in order to reduce interruption to traffic flow along these major thoroughfares and to contribute to the connectivity and integration of built-form within the Sector;
- (vii) enhance the accessibility of the site for pedestrians and cyclists through the inclusion of pedestrian linkages between the site, Lake Eden and surrounding areas;
- (viii) follow best practice environmental principles to minimise environmental harm and protect amenity of the area.

3.3 DEVELOPMENT REQUIREMENTS

3.3.1 In respect of every development in this Sector which involves the erection of a building, the person who undertakes that development or uses the site must, as part of that development or use, unless already provided:

- (i) construct a full width pedestrian pavement to Council's specification for the full length of those road frontages required by Council to the development site;
- (ii) construct concrete kerb and channeling to the Council's specification for the full length of each road frontage to the development site;
- (iii) construct reinforced concrete industrial crossings to the Council's specification from the kerb and channeling to the property alignment of the development site at approved locations where vehicular access to the development site is required;
- (iv) provide drainage work specified by the Council as necessary in connection with the works set out above including debris traps where drainage discharges directly or indirectly to the lake and/or waterway system;
- (v) provide reticulated sewerage and water supply adequate for the purpose of the development by connection to the Council's services in accordance with the requirements of the Council; and
- (vi) bear the cost of any alteration necessary to public utility mains, services or installations involved in the construction of the works referred to in this clause.

Any works within the road reserve must be undertaken in accordance with the North Lakes Town Centre design manual.

3.3.2 In respect of every development in this Sector the person who undertakes that development or uses the site must:

- (i) have all buildings designed by a registered architect and all landscaping designed by a qualified landscape architect;
- (ii) not impose a load on any public utility including the disposal of wastes, greater than that which is contemplated by the provisions of this Sector Plan; and
- (iii) not cause interference with the amenity of the area by the operation of machinery or electrical equipment, or from light, noise, vibration, smell, fumes, smoke, vapour, steam, soot, ash, grit, oil, dust, waste water, waste products, electrical interference or otherwise.

3.3.3 Requirements for Staging of Development

- (i) On completion of work in any stage, the remainder of the lot must be cleared of all rubble, debris and construction material and equipment and landscaped to the satisfaction of Council so as to be capable of being maintained.
- (ii) Each stage must form a coherent development and any future development sites must be provided with temporary landscaping, so the presentation of the lot to the street does not give a temporary or partially completed appearance.

3.4 STANDARD DESIGN & SITING MEASURES

3.4.1 Building Setbacks

Building setbacks are to:

- (i) Be generally constructed up to the 3 metre landscape strip along the frontage of Memorial Drive and Discovery Drive (where outdoor dining can also be accommodated within this setback). The length of building extending from this corner will be determined by architectural merit;
- (ii) be consistent with surrounding development to provide continuity in streetscape treatment; and
- (iii) generally be developed up to any pedestrian thoroughfares (not being a road).

Refer to *Figure 4 - Sector Plan Map*, indicating setback distances for the Sector.

3.4.2 Site Coverage

Site coverage and associated plot ratio are not restricted, provided the following elements are appropriately and adequately addressed by the design of the development:

- (i) architectural articulation and an appropriate level of design;
- (ii) well-presented frontages that provide a recognisable entrance;
- (iii) development is in context with, and visually compatible with the appearance of any neighbouring buildings;
- (iv) pedestrian facilities including pedestrian shelters are provided at ground level; and
- (v) sufficient on-site car parking is provided.

3.4.3 Building Design

Buildings proposed in the Sector must:

- (i). be in context with and visually compatible with the height, scale and bulk of surrounding development and streetscape patterns;
- (ii). not exceed the height of buildings on adjacent sites by more than two (2) storeys for those portions of the buildings adjacent to and visible from the street or pedestrian areas;
- (iii). where building heights exceed three (3) storeys in height, urban design assessment of the need to setback the taller components of any building to create a podium must be undertaken. The assessment must address at least the impact of bulk and form on the streetscape and pedestrian environment in the immediate vicinity, as well as the impact of overshadowing.
- (iv). allow sensitive environmental responses to slope, access and integration requirements;
- (v). be designed with attractive rooflines that complement the overall building design, are compatible with surrounding commercial roof form and roof pitch and include varying elements for visual interest;
- (vi). Flat rooflines are permitted for residential apartments which will complement the character of surrounding commercial buildings;

- (vii). include a combination of design elements to reduce building bulk, scale and mass, such as projections, recesses, openings and variations in light/shade and three dimensional form, banding in surfaces, external framing, entry structures, pergolas and subtle variations in parapet design;
- (viii). include large windows and/or balconies at upper levels which provide for viewing of external areas;
- (ix). create an attractive presentation to all road frontages and external pedestrian thoroughfares through the use of clearly articulated and well proportioned access doorways, landscaping and generally no more than two (2) rows of carparking and a centre manoeuvring aisle in front of the building (where parking is not to dominate the site);
- (x). complement the overall character of the Sector and the DCP area generally, whilst allowing corporate identity for tenants;
- (xi). incorporate materials and colours that are not highly reflective to avoid unreasonable glare nuisance to surrounding development; and
- (xii). for all non-residential buildings greater than 2500m² within this Sector, an Energy Efficiency and Water Efficiency Report must be submitted with the application for the Development Permit for Building Works. This report is to be certified by a suitably qualified person that the building generally complies with the energy efficiency guidelines in this Sector Plan.
- (xiii). Where openings are not provided to building facades located in proximity to the corner, maximise glazing at the ground floor level where appropriate;
- (xiv). orientate main public entrances to address the road frontage and provide well-lit pedestrian access and vehicular access to the street environment;
- (xv). present an attractive and functional façade to car parking areas and any pedestrian thoroughfares at the rear of development through use of horizontal and vertical variations and other design features that are consistent with the primary façade of the building;
- (xvi). ensure the Memorial Drive and Discovery Drive façades of a building addresses the street;
- (xvii). be of an open-framed, light-weight appearance, possibly including layered façade treatment along Memorial Drive and Discovery Drive; and
- (xviii). provide attractive facades and entries through the use of horizontal and vertical variations in the façade, and other design features.

3.4.3.1 Building Design Guidelines

Building design within the Sector is encouraged to:

- (i) be of low to medium rise, with a minimum height of three (3) storeys and a maximum of four (4) for residential buildings;
- (ii) include innovative contemporary building design derivative from Queensland building traditions, and designed to suit the climate, light and local culture;
- (iii) be designed to be multi-purpose and easily adapted for future changes;
- (iv) ensure that buildings relate physically and functionally with each other in terms of their architecture, location of major entries and any changes of level across the Sector; and
- (v) ensure that the design and location of any buildings or structures within the Sector take account of:
 - (i) topography and the preference to minimise site earthworks;

- (ii) drainage;
- (iii) soil conditions;
- (iv) services;
- (v) orientation towards focal points;
- (vi) aspect to maximise comfort and achieve energy savings;
- (vii) microclimate considerations;
- (viii) pedestrian movement patterns;
- (ix) vehicular access to avoid or minimise conflict points with pedestrians;
- (x) streetscape and landscape design;
- (xi) adjoining developments;
- (xii) minimising the effect of overshadowing on pedestrian areas;
- (xiii) the functioning of Memorial Drive and Discovery Drive;
- (xiv) landscape screening of retaining walls and other elements with low visual amenity; and
- (xv) views and vistas to prominent built and topographic features.

3.4.4.2 Material, Finish and Colour Guidelines

Building design within the Sector is encouraged to:

- (i) reflect a distinctive contemporary architectural style, with buildings sharing a palette of compatible finishes, colours and details that contribute to a strong sense of place;
- (ii) use materials and colours relating to those in the local environment, including the use of key character elements, for example, block stone work may be incorporated into the base of buildings to relate to the stone detailing within various public elements within North Lakes. Other key character elements may include the use of timber detailing, earthy tones, heavy plinth bases and feature species planting;
- (iii) include the integrated use of elements such as timber, glass and tin;
- (iv) include corrugated pre-finished and coloured metal sheets for major roofing materials. The application of these materials must minimise any reflective nuisance to surrounding development;
- (v) incorporate brighter colour accents for minor detail elements such as window and door frames, columns, handrails, ornamental features and signage details; and
- (vi) incorporate materials that:
 - (a) are robust, durable and resistant to vandalism;
 - (b) present a suitable finish to pedestrian areas;
 - (c) incorporate walls which present as solid and permanent elements;
 - (d) are of a high quality, clean and free of defects;
 - (e) are low maintenance,
 - (f) assist with thermal performance and energy efficiencies, where practicable.

3.4.4.3 Design for Microclimate and Energy Efficiency Guidelines

Building design within the Sector is encouraged to:

- (i) include the use of external shade structures, ventilated spaces, overhangs and screens to allow enjoyment of the outdoors while also providing relief from the sun, wind and rain;
- (ii) provide ventilated roof cavities by taking advantage of prevailing breezes;
- (iii) maximise the use of adequate and effective insulation materials in roof cavities and wall spaces of buildings in order to maximise comfort and minimise demands for energy required for air-conditioning;
- (vii) where possible, orientate buildings to minimize westerly sun exposure and maximize northerly exposure and solar access in the winter;
- (viii) articulate and shade external walls, and particularly the longer external walls, with eaves, over-hangs, sills or other treatments to reduce the exposure to direct sunlight, heat and glare, while windows in external walls should be recessed or shaded wherever possible to achieve energy savings;
- (ix) restrict the use of highly reflective materials on external walls or windows as a means of minimising energy requirements and excessive sunlight, glare and heat into adjoining developments;
- (x) incorporate the use of instantaneous gas, solar hot water heaters, heat pumps and/or solar energy devices;
- (xi) implement energy efficient management systems for the building;
- (xii) where possible, use building materials with high insulation values particularly for roofs and walls;
- (xiii) provide cross-ventilation and operable windows where buildings are able to catch prevailing breezes;
- (xiv) where possible, orientate buildings to minimize the potential impacts of cold westerly winds in winter and maximize cooling breezes from the south in summer; and
- (xv) design and landscape car parking areas to reduce the impacts of reflected heat and glare into adjacent buildings, and to reduce the effects of heat storage during summer months.

3.4.4.4 Water Efficiency Guidelines

Development within the Sector is encouraged to:

- (i) collect and store roofwater for toilet flushing and landscape use; and
- (ii) minimise water consumption through incorporation of flow restrictors, AAA rated water efficient taps and shower roses and dual flush (3/6 litre) cisterns.

3.4.5 **Safety and Crime Prevention**

The design and siting of any structures, landscaping, buildings and public spaces must:

- (i) avoid obscured corners and narrow or dead-end alleys;
- (ii) maximise the opportunity for casual surveillance of public spaces and car parking areas from surrounding buildings, roads and pedestrian areas;
- (iii) include lighting of public places; and
- (iv) include, for a use with a gross floor area of 2,500m² or more, an Environmental Design assessment such as Crime Prevention Through Environmental Design (CPTED) or similar crime prevention safety audit, which must be undertaken

by applicants during the design phase and properly taken into account in the final design of the project. A copy of the assessment shall be provided to Council at the time of lodging each development application for a Material Change of Use. This assessment is to have due regard to the design and maintenance of buildings and external areas within the Sector, as well as the factors outlined in this sub-section.

3.4.6 Lighting & Glare

Lighting and Glare Management within the Sector must:

- (i) wherever possible, include architectural floodlighting of a building or space through the integration of the luminaries into the fabric of the building;
- (ii) ensure lighting systems are designed to prevent direct and/or reflected glare to surrounding areas. This applies particularly to disabling and uncomfortable glare to pedestrian and vehicular movement or at entrances, steps, stairs and pedestrian paths;
- (iii) ensure that where lighting is provided within landscaped areas, the choice and location of lighting allows for plant and tree growth and will not become obscured as the landscape matures;
- (iv) include safety lighting in open space and car parking areas that may be used at night-time;
- (v) ensure permanent strobe, laser, flashing, oscillating, moving or alternating lights are not permitted in locations within the Sector where they are likely to cause a nuisance;
- (vi) have regard to the efficiency of energy consumption in the design of lighting systems; and
- (vii) comply with the requirements of AS4282 – *Control of Obtrusive Effects of Outdoor Lighting*.

3.4.7 Plant & Equipment

The design and siting of plant and equipment must comply with the following requirements:

- (i) all air conditioning and ventilation plant and other equipment located on the roof or externally around the building are to be treated as an integral part of the building form and be suitably screened from view to match with surrounding materials;
- (ii) where lift motor rooms, plant rooms and the like are proposed, they are to be treated as an integral part of the building form in order to create a coherent roofscape;
- (iii) environmental management structures or control devices, such as gross pollutant traps, waste disposal bins, flues and the like are to be designed so as not to detract from the overall visual character of the town centre or the immediate area;
- (iv) contain design elements and buffer treatments to control any obtrusive effects where it is likely to adversely affect residential amenity, visual aesthetics, public safety and traffic safety;
- (v) if necessary, adopt effective air pollution mitigation measures to comply with

the *Environmental Protection Act, Environmental Protection Policy (Air)* and other relevant legislation in relation to dust, smoke, fumes and gases, where necessary; and

- (vi) if necessary, adopt effective noise pollution mitigation measures to comply with the *Environmental Protection Act, Environmental Protection Policy (Noise)* and other relevant legislation, where necessary.

3.4.8 Telecommunications Equipment

Telecommunications equipment is to be:

- (i) generally co-located with other telecommunications equipment installed in the Sector;
- (ii) constructed in a form complementary to the façade and roofline of the building on which it is to be mounted; and
- (iii) where possible, coloured so as to blend in with the background of the building on which it is to be mounted.

3.4.9 Regrading

The earthworks approach for the Sector must:

- (i) ensure that changes of level at the site boundary allow non-discriminatory access to each allotment from the road frontage/s and to adjoining allotments, where possible;
- (ii) take into account the efficient management of earthworks;
- (iii) consider the visual impact of any batters and/or retaining walls along the Memorial Drive and Endeavour Boulevard frontages;
- (iv) be generally in accordance with surrounding approved Sector Plans;
- (v) achieve a high level of functional and visual integration between surrounding areas; and
- (vi) must be detailed & accompany any future application for material change in use.

3.5 SPECIFIC MEDIUM DENSITY APARTMENT DESIGN AND SITING GUIDELINES

As a medium density residential development, the design and siting of all dwellings within the sector is to generally comply with the acceptable solutions outlined in the Integrated Development Guidelines of the *Queensland Residential Design Guidelines (QRDG)*. In addition to, or by way of further qualification of, the Integrated Development Guidelines outlined in section 3.5 are to also be complied with in the development of the sector.

The following Medium Density Residential Design and Siting Guidelines for North Lakes are to be complied with in the development of any medium density housing sites on the Sector Plan Map Figure 4 within Town Centre Frame “H” Sector Two:

3.5.1 Building Controls

- .1 Site coverage is limited to 50%. Site coverage is defined as that portion of a site covered by a building (including garages), fixed

structure, or outdoor storage area, but not including unroofed parking areas, basement car parking (which does not project greater than 1m above finished ground level as at the date the lots are created) and roof eaves.

Pergolas, gazebos, verandahs, shade structures and other leisure and recreational purpose areas (whether fully roofed or not) are included in site coverage. These semi-enclosed outdoor structures are permitted to a further maximum building site coverage of 10% of the total lot area.

.2 Buildings within the Sector must:

- (i) be a minimum three (3) storeys in height above the finished ground level; and
- (ii) not exceed four (4) storeys in height.

3.5.2 Building Setbacks

.1 Building setbacks are to be:

- (i) no less than three metres from the front boundary alignment
However, unenclosed spaces such as verandahs, terraces, balconies and pergolas may project into the front setback by a maximum of 1.5 metres; and

.2 Eaves, excluding gutter, are permitted to extend up to 600mm within the setback areas (other than where buildings are built to a zero lot line boundary).

3.5.3 Landscaping

.1 Landscape planting is to be provided, wherever practicable, to soften the appearance and give scale to buildings and a 3 metre landscape setback to all street frontages of each lot in the Sector.

.2 Of that part of the lots within the sector not used for buildings, driveways and parking (ie. the balance area), the use of permeable or absorbent finishes, eg. grass, planting or garden beds, is to be maximised. A minimum of 25% of the lot area is to be absorbent landscaping.

.3 Along the perimeter of the sector, trees and shrubs are to be planted of a species likely to grow to provide a landscape canopy between the buildings within the sector and the adjacent (external) properties and major roads. The size, layout and density of trees planted in the setback areas are to take account of the need for landscaping as privacy screening, as well as useable outdoor space and solar access considerations.

3.5.4 Building Appearance

- .1 Each dwelling unit within a building is to have:
 - (i) At least one habitable room and windows of appropriate proportions facing the primary street frontage; and
 - (ii) At least one habitable room and windows of appropriate proportions on each storey facing a secondary street.
- .2 The building façade fronting the primary street frontage must incorporate the following design elements:
 - (i) A minimum of 10% of the façade area of each dwelling unit must be either windows or glass; and
 - (ii) One of the following:
 - (a) A defined central entry where a shared entry/lobby area provides access to multiple dwelling units within a building; or
 - (b) Separate defined entry points for all dwelling units with an individual access point.
- .3 The building façade facing a secondary street or have a common boundary with a park must incorporate the following design elements:
 - (i) A substantial balcony, verandah, patio or other covered outdoor entertaining area for each dwelling unit in a building; and
 - (ii) Building recesses or projections incorporating articulated plan form; and
 - (iii) A minimum of 20% of the façade area of each dwelling unit must be either windows or glass.
 - (iv) Where a horizontal length of a wall has a height of three or more storeys, it is not to be greater than 15 metres in length in one plane (i.e. where external faces offset one metre or more are not provided for that the length of wall).
 - (v) All entrance foyers must include either sidelight or highlight windows in the entry alcove. The only exception is when a set of double doors are used.
 - (vi) The material to be used to infill above windows and doors on a façade facing a street or public area must be the same material and colour used on the remainder of that façade.
 - (vii) Each dwelling unit is to provide an internal storage area with a minimum volume of 8m³. This storage area may form part of the garage. Freestanding sheds are not permitted.
 - (viii) A minimum roof pitch of 25 degrees is required for the portion of the roof viewed any street frontage or common boundary with a park. Innovative roof designs incorporating curved, flat or skillion elements will be assessed on their individual architectural merits by Council in consultation with the principal

developer. Skillion roof designs are required to have a roof pitch of a minimum of 15 degrees.

- (ix) Flat rooflines are permitted for residential apartments which will complement the character of surrounding commercial buildings;
- (x) Ground level open type pergolas may be built abutting any side boundary. No part of any such structure abutting a side boundary is to be attached to the wall of an adjoining building.
- (xi) All external plumbing (waste pipes and vents) must be concealed within wall cavities.
- (xii) The underside of decks should be properly finished to compliment the building and screened from public view.

3.5.5 Building Colours and Materials

- .1 The requirements of Section 3.4.4.2 apply.

3.5.6 Garages/Carports

- .1 All dwelling units are to provide under cover car parking spaces in accordance with the rate specified in Section 3.5.8.
- .2 Where a garage is integrated into the building design of an individual dwelling unit, the garage must be:
 - (i) setback a minimum of 6 metres to the front boundary alignment; and
 - (ii) setback a minimum of 900mm from the front building line (the front building line is a line that contains no less than 3.5 metres of the dwelling excluding unenclosed spaces); and
 - (iii) covered by an enclosed three storey section of the dwelling or a roofed verandah or balcony (provided that it and the balustrading has a minimum transparency of 50%) extending over the entire width and depth of the garage.
- .3 Basement car parking (whether provided for an individual unit or in a shared car parking arrangement) is permitted where:
 - (i) a minimum setback of 3 metres to the front boundary alignment is provided; and
 - (ii) an enclosed three storey section of the dwelling or a roofed verandah or balcony (provided that it and the balustrading has a minimum transparency of 50%) extends over the entire width and depth of the garage; and
 - (iii) The garage does not project greater than 1 metre above finished ground level as at the date the lot was created to the top of the slab is permitted where that area projecting above ground level is suitable screened with landscaping. For the purposes of calculating the maximum site coverage, basement car parking which projects no greater than 1m above finished ground level will not be included.
 - (iv) Garage roller doors will be considered on their architectural merit where they complement the design of the dwelling.

3.5.7 Boundary Fencing

- .1 If constructed, a front wall or fence (including gates) is to be:
 - (i) a maximum of 1.8 metres high; and
 - (ii) constructed of rendered and painted masonry piers and base (minimum 300mm base), and infills of matching masonry, coloured metal tube and painted or treated timber lattice or battens; and
 - (iii) a minimum 25% transparent.
 - (iv) Solid pre-coloured metal fencing is not permitted.
 - (v) 'Soft' enclosures and demarcations of the front property boundary, e.g. hedges, earth mounding and landscape planting, are encouraged. Where hedges are established to delineate a front boundary, gates may be incorporated, providing established and vigorous plantings are utilised for hedges;
 - (vi) Set back 3 metres from road frontages.

- .4 All side and rear fencing must be:
 - (i) A maximum of 1.8 metres high;
 - (ii) Set back 1 metre behind the front wall of the dwelling;
 - (iii) constructed of face brickwork or rendered and painted masonry piers (either with or without masonry base) and/or hardwood timber posts; and
 - (iv) infills of coloured metal tube.

- .5 Where the principal developer has constructed a fence, it must be maintained by the owner to the standard at which it was constructed.
- .6 Retaining walls are generally not permitted between the rear of the building and the rear fence, unless integrated with terraced garden beds.
- .7 Retaining walls must be designed to complement the style of the home and must not exceed 1.0m in height.

3.5.8 Carparking

- .1 Carparking within the sector is to be provided at the minimum rate of 1.5 spaces per dwelling unit of which at least one space is to be fully enclosed, plus 0.5 spaces per dwelling unit for visitor parking.

3.5.9 Driveways

- .1 An internal access road will provide access from the primary street as indicated on the Sector Plan to reduce interruption to traffic flows.
- .2 Driveways providing access to parking areas (i.e. being either a shared basement car parking arrangement or individual garages/carports) must be completed prior to occupation of dwelling units. Acceptable finishes for driveways are:

- (i) coloured concrete pavers constructed on a concrete base, clay pavers or natural stone pavers constructed on a concrete base; or
- (ii) stencilled concrete; or
- (iii) exposed aggregate.
- (iv) Plain concrete driveways are not permitted except within the road reserve to finish between a public footpath and the kerb.

Other driveway finishes may be considered on their merits by Council in consultation with the principal developer and, if acceptable, are to be recorded in Council’s ‘North Lakes Register of Alternative Acceptable Design Solutions’.

- .3 Where a garage is integrated into the building design of an individual dwelling unit the driveway must be no wider than 6.0 metres at the garage door and provide at least 500mm of landscaping either side of the driveway.
- .4 Driveways are to be paved for their full width (ie. “car tracks” are not permitted).
- .5 The maximum grade for driveways is 1:5. All driveway grades from the property boundary (not the kerb) to the garage are to conform with the North Lakes standard drawings for residential driveway layout and construction. The profile of the section of driveway between the front property boundary and the kerb is to follow the Council approved grade.
- .6 If a crossover is provided and not used then it must be removed and the verge and kerb must be constructed at the owners cost, to Council’s standard.
- .7 If a footpath has been constructed in front of the property the driveway must abut and not cut through the footpath. The balance of the driveway between the footpath and the kerb may be plain concrete to match the footpath.

3.5.10 Ancillary Structures

.1 *Signs*

Signs and hoardings for advertising products and businesses are not permitted on residential lots with the exception of businesses being undertaken from home within the definition of a detached house, approved home occupations or display home signage, which may only be erected with the prior approval of the principal developer. Builders/tradespersons’ signs are permitted where they are required on lots but only during construction.

.2 *Air Conditioners*

Air conditioners are to be located below the eaveline and screened from public view. Air conditioning units may only be permitted above the eaveline if they are of a low profile and coloured to match the roof colour.

Roof-mounted or unscreened wall and window mounted air conditioning units facing the street or parks are not permitted.

.3 *Television/Radio Antennae & Satellite Dishes*

Internal or under the roof antennae are encouraged. An external antennae, if required, is to be located towards the rear of the dwelling. Satellite dishes are only acceptable below the roof line.

.4 *Solar Water Heaters*

Where practicable, solar water heaters are to be located on roof pitches which minimise their visibility from public areas. Solar collector panels are to lie on the roof and not be supported on a frame. Where practicable, storage tanks are to be detached and concealed from view by locating them within the roof space.

.5 *Other Structures*

Clotheslines, hot water systems, gas systems, fuel storage tanks, rainwater tanks and meter boxes are to be screened or located away from any street or park frontage.

.6 *Unightly Objects*

To maintain an attractive overall streetscape, trucks, caravans, boats or trailers are not permitted to be parked on lots unless they are completely housed within a garage or screened from public view.

3.6 LANDSCAPING / TOWNSCAPING

3.6.1 Landscape/Townscape Concept

The landscape framework for the Sector is represented by the design principles shown indicatively on *Figure 5 – Sector Landscape Plan*.

3.6.2 Character

The Memorial Drive streetscape is to be consistently framed with appropriate landscape and canopy trees to continue the species-themed “boulevard” entry to North Lakes which may be further activated through the incorporation of outdoor dining. Streetscape treatment along this frontage includes a planted medium, generous footpaths, street trees, on-street parking and lighting. The “boulevard” is envisaged as a wide streetscape displaying a very open character.

The Discovery Drive streetscape is to be consistently framed with appropriate landscape and canopy trees to continue the species-themed “boulevard” entry to North Lakes, which was conceptualised as part of Town Centre Frame “C” Sector One (Sector 019-1000) and Town Centre Frame “C” Sector Two (Sector Plan 019-2000). Streetscape treatment along this frontage includes generous footpaths, street trees, on-street parking and lighting. The “boulevard” is envisaged as a wide streetscape with a very open character. Street treatments and landscaping should clearly indicate the

through-route nature of the road and give views to the parking entrances of development.

Landscaping shall promote safety and low speeds, but with due concern for maintaining driver's sightlines. Landscaping within private development sites must reinforce the landscaping within the street frontages. Landscaping is required to buffer and screen functional elements of uses such as car parking along these frontages to reduce their impacts upon the amenity and visual character of the Sector.

Where building heights exceed three (3) storeys, consideration should be given to additional setbacks of the upper levels of any building which will serve to create a podium where additional landscape treatment could be incorporated and provide for further articulation of the built form.

3.6.3 Requirements

Landscaping in the Sector must:

- (i) correspond with the design principles illustrated on *Figure 5 – Sector Landscape Plan*;
- (ii) generally achieve the landscape character described above and the landscape concept described in section 4.2 of the Precinct Plan;
- (iii) provide a minimum landscaped strip of three (3) metres along Memorial and Discovery Drive frontages of each lot within the Sector;
- (iv) provide a minimum landscaped strip 1.5 metres along internal boundaries to separate parking areas;
- (v) be designed to complement and integrate with the landscaping and design character of adjoining Sectors and Precincts;
- (vi) include canopy trees, planted by the Principal Developer, generally with a minimum clear trunk of 1.8 metres planted at informal intervals within the road reserve of Memorial Drive and Discovery Drive. Street trees are intended to provide visual continuity to the street, reduce the road scale and provide shade to on-street car parking and adjacent pedestrian areas;
- (vii) reduce the appearance of an expanse of car parking areas by providing advanced shade trees at the rate of not less than one (1) tree per six (6) parking spaces and by providing low plantings along car parking aisles which do not impact on driver's sightlines;
- (viii) screen car parking areas from roads and other areas readily accessible to the public but occasional views of key elements of each proposed building may be provided;
- (ix) provide adequate landscaped areas so as to create a landscape setting and passive recreation space for development;
- (x) allow for pedestrian linkages and landscape planting extending from entry points to development sites within the Sector to connect, where possible, through car park areas to the pedestrian pathway associated with internal driveways;
- (xi) be employed to reduce reflected glare from building facades;
- (xii) not compromise pedestrian safety from vehicles accessing sites within the Sector or in surrounding development;

- (xiii) be capable of efficient and effective maintenance;
- (xiv) generally frame entry areas to sites;
- (xv) screen services such as electricity substations and transformers in a way that does not affect the streetscape;
- (xvi) delineate between the pedestrian and vehicular environments, as well as to provide some relief from headlight glare and visual monotony; and
- (xvii) where retaining walls or batters are required, provide a landscape buffer located clear of these works to reduce the impact of the wall if visible from a street. Retaining walls and batters must be of a scale and materials that complement the surrounding built environment while responding to landform.

3.6.4 Fencing - General Requirements

The requirements for fencing within the Sector are set out below:

- (i) No fencing in proximity to road boundaries is permitted (other than permitted in Section 3.6.5 below).
- (ii) if fencing is proposed to side and rear boundaries and is to be constructed of timber and the height of the fence must not exceed 1.8 metres . Other fencing materials may be considered as part of the material change in use application. Any fencing must be setback three (3) metres behind the alignment of the front façade on any building.
- (iii) 'Soft' enclosures and demarcations of the front property boundary, e.g. hedges, earth mounding and landscape planting, are encouraged. Where hedges are established to delineate a front boundary, gates may be incorporated, providing established and vigorous plantings are utilised for hedges.
- (iv) Where the principal developer has constructed a fence, it must be maintained by the owner to the standard at which it was constructed.
- (v) Retaining walls are generally not permitted between the rear of the building and the rear fence, unless integrated with terraced garden beds.
- (vi) Earth/fill or retaining walls are not permitted within 3.0m of the rear boundary.
- (vii) Retaining walls must be designed to complement the style of the home and must not exceed 1.0m in height.

3.6.5 Fencing – Specific Memorial Drive and Discovery Drive Requirements

Where residential units are developed on lots 47, 48 and 51 additional fencing requirements are applicable for the setback of fencing to Memorial Drive extending around the entire Discovery Drive frontage of Lot 48 and part way along the internal road frontage of Lots 47 and 51.

- (i) Where residential units are developed at ground level fencing may be setback 1 metre within the 3 metre landscape setback where screened with planting to increase the courtyard area for ground level units. This fencing shall be of a high standard as per Fence Type 1 shown in *Appendix F. – Fencing Requirements* .
- (ii) If constructed, the front wall or fence (including gates) is to be:
 - (a) a maximum of 1.8 metres high; and
 - (b) constructed of rendered and painted masonry piers and base (minimum 300mm base), and infills of matching masonry, coloured metal tube and painted or treated timber lattice or battens; and

- (c) a minimum 25% transparent.
- (d) Solid pre-coloured metal fencing is not permitted.

3.6.6 Plant Species Guidelines

Planting within the Sector is encouraged to incorporate:

- (i) plant species themes that are consistent and complementary to surrounding development. The species of trees, shrubs, and groundcovers used within the Sector should be selected from the Plant List included in **Appendix B - Plant List**. Plants of similar characteristics may be substituted for a species in the Plant List, if approved by Council. The selection of landscape material is to be cognisant of safety considerations by excluding thorny or poisonous plants that may be hazardous;
- (ii) the use of native species as the predominant plantings to visually reflect the original natural setting of the DCP area, as well as offer benefits of reduced maintenance and water requirements. Exotic and flowering species may be used occasionally as feature planting, to announce entries to the Sector, to provide shade trees in public outdoor spaces, or as accents of colour and texture within the framework of native plant material; and
- (iii) planting densities and heights appropriate for particular areas such as vehicle sales yards, retaining walls and the like are to be shown on a Landscape Plan submitted as part of the Material Change of Use application.

3.7 CARPARKING, SERVICE AREAS & LOADING DOCKS

3.7.1 Carparking

Car parking in the Sector must:

- (i) be in accordance with the Planning Scheme requirements current at the time of lodgement of the material change of use application, the DCP and the Council's Design Manual.
- (ii) as part of the total car parking requirements, provide not less than one (1) car park per fifty (50) spaces (or part thereof) for people with disabilities;
- (iii) be controlled to minimise its impact on the surrounding road network, any internal circulation and other development adjacent to the Sector;
- (iv) provide safe pedestrian routes which focus on the connectivity between the site and adjacent development within the Town Centre Frame;
- (v) ensure that pedestrian movement areas through car parks to a building are clearly defined;
- (vi) where possible, provide opportunities for shared use of car parking between the Sector and adjoining Sector developments; and
- (vii) minimise the visual impact of any structured or basement car parking from the surrounding roads. Any structured parking is to be 'sleeved' behind development fronting Memorial Drive and Discovery Drive. Surface car parking may include shade structures within selected areas of the car park.
- (viii) Undercroft car parking visible from the street is to be suitable screened with a combination of landscaping, low level walls, (including rocks, earth mounds and batters), and screens (under floor or between columns) integrated within the building

design, to reduce the visibility of the undercroft car parking as well as unfinished building fittings, storage and plant areas, etc., to less than 50% of the area that would otherwise be visible from the street. A combination of all three of the above elements is to be implemented. Walls and screens should be a minimum of 600 mm in depth.

3.7.2 Bicycle Parking

Employee and customer bicycle parking spaces and the type of bicycle parking devices are to:

- (i) be generally in accordance with *Appendix C – Bicycle Parking Requirements*;
- (ii) include one (1) shower cubicle with ancillary change room per ten (10) bicycle spaces required by 3.7.2(i) above. Facilities may be utilised by both males and females provided adequate privacy and accessibility is ensured for both sexes; and
- (iii) if the demand for the bicycle spaces is not consistent with the table contained in *Appendix C*, Council, on a case by case basis, may permit a reduction of the number of end of trip facilities.

3.7.3 Access

The requirements for access are set out below:

- (i) indicative vehicular ingress and egress points from Discovery Drive are limited to the number of access points shown on the *Figure 4 – Sector Plan Map*. This access must limit turning movements to those shown on the sector plan map. However, the location of the access points may vary along the road provided other access restrictions noted on *Figure 4* are not compromised with no access permitted from Memorial Drive;
- (ii) restrictions to vehicular access have been noted indicatively on *Figure 4* by the inclusion of the "No vehicular access permitted" designation;
- (iii) vehicular access points at these locations should ensure no queuing occurs across pedestrian areas or causes interruption to traffic on the surrounding roads;
- (iv) Lot 48 as indicated on *Figure 4* has a separate left in left out access to the site;
- (v) Memorial Drive and Discovery Drive are to be developed as vehicular traffic priority streets;
- (vi) An internal access route is to service the Sector; with access via from the round-a-bout at Memorial Drive to Endeavour Boulevard which bisects the Sector;
- (vii) provide convenient and safe pedestrian and cyclist access within or to development adjacent to the Sector and to public transport facilities. Such access is to be integrated with the path and street system;
- (viii) consideration must be given to the design and location of access points adjoining the Sector so as to minimise potential conflicts with car parking areas, pedestrian areas, paths and service areas within the Sector;
- (ix) vehicular access lanes into the Sector are to generally be a maximum width of ten (10) metres and include at least one footpath of a minimum two (2) metres width;
- (x) adequate measures to achieve a high level of public safety on the shared access laneways / driveways is to be provided and, where appropriate, should include:

- (a) good visibility at all pedestrian crossings and establishing pedestrian priority, where appropriate;
- (b) pavement treatments which achieve a very low traffic speed, while permitting easy and even-surfaces for desirable walking conditions for pedestrians;
- (c) finishes that are in keeping with existing finishes within the road or the road verge;
- (d) suitable barrier treatments at the entrance points;

- (e) the provision of continuous pedestrian access between buildings, car parks and pedestrian areas; and
- (f) the provision of site and building illumination within car park areas, pedestrian areas and along pedestrian paths during the hours of operation of any component of the development and, at other times, by the provision of security lighting.

- (xi) ensure that no reversing of vehicles, particularly service vehicles, shall occur in areas of high pedestrian activity;
- (xii) direct access for emergency vehicles is to be provided to every building within the Sector by the provision of a minimum 3.5 metre clear carriageway width;
- (xiii) pedestrian access points via car parking areas at the rear of any development should be clearly identified and designed to maximise safety and convenience; and
- (xiv) access for all people including people with a disability is to be achieved by ensuring that development complies with Council provisions relating to access for people with disabilities.

3.7.4 Servicing Requirements

Development within the Sector must provide:

- (i) if required, loading zone parking which is to be accessed from the internal vehicle circulation areas;
- (ii) storage for refuse and recyclable materials which are suitably screened from circulation areas;
- (iii) service connection points incorporated into hard and soft landscaping areas;
- (iv) service connections that do not protrude from paving or driveways or cause any hazard for pedestrians or vehicles; and
- (v) where appropriate, provide landscaping and other screening devices to undesirable views of service areas, loading bays, refuse areas and plant and machinery, within the Sector and in adjacent Sectors.

3.8 SIGNAGE

Signage in the Sector must:

- (i) with respect to signage that identifies development within the Sector and associated development, be generally integrated with any frontage walls, entry statements or entry structures, if provided. This signage may be located along the frontage of Memorial Drive and Discovery Drive;
- (ii) be limited to signage integrated into any proposed buildings;

- (iii) where appropriate, include directional signage for visitors which may include logos/names of the use;
- (iv) consist of high quality materials, form, scale and proportions and be coordinated to the built form throughout the Sector, while providing sufficient flexibility for corporate identification and marketing purposes;
- (v) ensure that lighting of any signage will not cause a nuisance to drivers or pedestrians;
- (vi) be visible, legible and not result in a cluttered or discordant streetscape;
- (vii) provide limited use of highly reflective finishes;
- (viii) incorporate professional and coordinated graphics;
- (ix) not permit bunting, streamers, sandwich boards and other low-quality, temporary, or opportunistic signs; and
- (x) ensure that any support structure or cabling to illuminate signs will not be visible.

3.8.1 Signage Guidelines

- (i) Signage guidelines are included at *Appendix D - Town Centre Signage Guidelines*. The Signage Guidelines are to be taken into consideration, along with other relevant issues, when considering matters regarding signs and architectural graphics of all kinds. They are not to be interpreted as giving rights to any number or types of signage.
- (ii) A Coordinated Signage Plan is to be submitted with any development application for Material Change of Use within this Sector. The Coordinated Signage Plan must distinguish between artworks/murals, on-site business advertising, animated signage, and “third party” advertising in terms of sign dimension, location, illumination, and animation on the face of the sign.

4.0 Environmental Management

There is no Environmental Management Plan having application to this Sector.

Management systems for land within the Sector must be implemented to ensure that the Objectives and Performance Indicators referred in the following sections of the Precinct Plan continue to be met throughout the life of the development and the use of the Sector:

- (i) Section 5.1 – Environmental Management Objectives;
- (ii) Section 5.2 – Stormwater Management Objectives; and
- (iii) Section 5.3 – Earthworks Management Objectives.

5.0 Subdivision Requirements

As shown in *Appendix E – Proposed Metes and Bounds Description* the total area of the Sector is 2.134 hectares.

The indicative area and frontage width of the allotment within the Sector is shown on **Figure 6 - Indicative Plan of Subdivision**.

Access to future allotments within the Sector is to be from Discovery Drive and the internal road; however access should be in line with areas of the site affected by the "No vehicular access permitted" designation.

Reciprocal access easements are to be created in order to provide shared access for all adjoining allotments and future uses in line with those illustrated in **Figure 4- Sector Plan**.

The minimum area and frontage of any future proposed allotment within the Sector is to be as follows:

- (i) Minimum Lot Area 1,800m²
- (ii) Minimum Frontage Width 30m

6.0 Infrastructure

6.1 INFRASTRUCTURE TO BE PROVIDED

The infrastructure required to be provided by the Principal Developer to serve the Sector includes internal and external infrastructure provisions in accordance with the Rezoning Conditions, the Mango Hill Infrastructure Agreement 1999 (MHIA) and agreements made with the State Government in accordance with the DCP. These obligations are summarised as follows:

6.1.1 Roads

All roadworks required by the MHIA and where applicable, the Mango Hill Agreement – Main Roads (MHIA – MR), associated with this sector have been completed. (refer to **Figure 7 – Road Layout**).

- (i) (refer to **Figure 7 – Road Layout**)

6.1.2 Water Supply

- (i) Reticulation systems along all internal roads to service all properties in the Precinct;
- (ii) Those sections of the mains shown on **Figure 8 – Water Supply Headworks**, necessary to service the anticipated demand in the Sector; and
- (iii) Make contribution towards water headworks and bulk water supply in accordance with the MHIA.

6.1.3 Sewerage

- (i) Trunk gravity main from the existing Council sewerage infrastructure to connect with each lot in the Sector as shown on *Figure 9 – Sewerage Headworks*; and
- (ii) Make contribution towards sewerage headworks supply in accordance with the MHIA.

6.1.4 Park

The requirements for park provision throughout the DCP area are provided for the MHIA . Additional park will be required in accordance with 7.3.1 of the MHIA.

6.1.5 Stormwater

- (i) The Principal Developer must comply with the provisions of the Stormwater Management Plans for Saltwater Creek and Tributary C as approved by Council and construct stormwater management works so far as they relate to this Sector.
- (ii) Stormwater management works so far as they relate to the Sector are to be provided in accordance with the MHIA, Council's Design Manual, the Stormwater Management Plan for Tributary C, including the construction of all drainage and landscaping works in Tributary C and the Stormwater Management Plan for Saltwater Creek.
- (iii) In addition, the Principal Developer is to construct stormwater drainage systems and stormwater management systems as required by the MHIA and the Environmental Protection (Water) Policy.

6.1.6 Electricity Supply, Lighting and Communications

- (i) Allow for underground electricity distribution to all properties within the Sector, by Energex or another appropriate supplier of electricity.
- (ii) Arrange for the provision of underground conduits along all road verges within the Sector and adjacent roads to meet the anticipated demands of the DCP area.
- (iii) Provide underground electricity to all properties within the Sector through Energex or another appropriate supplier of electricity and to Council standards.
- (iv) Provide public lighting to all roads, streets and if relevant, parks and other public areas and facilities within the Sector and along Memorial Drive and its intersection with Endeavour Boulevard, constructed to relevant Australian Standards and in accordance with the requirements of Energex or alternative supplier of electricity and Council standards.
- (v) Provide high voltage electricity services to the Sector through Energex or another supplier of electricity and to Council standards.
- (vi) Provide all electricity services and distribution systems as underground services, including conduits along all road verges within the Sector and adjacent roads to meet the anticipated demand of the DCP area.

6.2 INFRASTRUCTURE AFFECTED OR REQUIRED BY DEVELOPMENT OF THE SECTOR

- (i) The development of the Sector may place demands on the following infrastructure:
 - (a) Roads external to the DCP area and the Sector;
 - (b) Water supply infrastructure;
 - (c) Sewerage infrastructure;
 - (d) Stormwater infrastructure;
 - (e) Parks;
 - (f) Community facilities;
 - (g) Electricity and gas supply;
 - (h) Communications systems; and
 - (i) State Government Infrastructure.
- (ii) The infrastructure described in clause 6.1 above, together with the obligations of the Principal Developer under infrastructure agreements will mitigate the adverse affects on the above infrastructure.

6.3 HOW THE REQUIRED INFRASTRUCTURE RELATES TO THE INFRASTRUCTURE AGREEMENTS

The infrastructure agreements describe the infrastructure that must be provided by the Principal Developer as part of its obligations to provide infrastructure, as envisaged by Chapter 12 of the DCP. The works described in clause 6.1 of this document are the Principal Developer's obligations under the rezoning conditions and the infrastructure agreements.

7.0 Detailed Infrastructure Program

7.1 ESTIMATED DATE FOR PROVISION OF INFRASTRUCTURE

The Principal Developer is to provide the infrastructure referred to in clause 6.1 of this document at times to satisfy the requirements of the MHIA. The majority of the infrastructure has been completed during 2005.

7.2 INTENDED PROVIDER

The Principal Developer is to provide the infrastructure referred to in Section 6.1 at times to satisfy the requirements of the Rezoning Conditions and the MHIA which provides for the infrastructure to be constructed to meet the rate of development in the Sector.

7.3 OTHER WORKS DEPENDENT ON INFRASTRUCTURE PROVISION

No other works depend on the provision of the infrastructure specified in Section 6.1. Council is to use its best endeavours, including its powers of resumption if lawful, to obtain all necessary rights to permit the construction of water and sewerage infrastructure if such infrastructure is constructed on land external to the DCP area over which Council does not have such rights.

7.4 OTHER RELEVANT INFORMATION

7.4.1 Estimated Water and Sewerage Demands

As required by the MHIA, the Principal Developer states as follows:

For the purpose of assessing water supply capacity, the estimated number of equivalent Tenements for this Sector is 61.65ET's;

For the purpose of assessing sewerage capacity, the estimated number of Equivalent Persons for this Sector is 254.9EP's and

- (i) if a future alternative use of the Sector imposes a greater demand on minimum water supply and sewerage infrastructure than assigned in an approved development site within this Sector, Council is to approve the alternative use provided the developer demonstrates that:
 - (a) to do so will not adversely impact on minimum water supply and sewerage infrastructure standards within the DCP area and elsewhere if considered appropriate by the Council's engineer having taken into consideration development approved in the DCP area at the time of an application and future development in the DCP area as provided for by the DCP;
 - (b) the principal developer has confirmed, in writing, that the increase demand will not prevent servicing the total number of ETs or EPs provided in the MHIA; and

In the event the developer satisfies Council of the requirements in (a) and (b) above, the Council will require the payment of headworks charges for ETs and EPs not already paid in respect of the proposed development.

APPENDIX A

FINAL SPECIFICATION

OF LAND USE

FOR THIS SECTOR

**FINAL SPECIFICATION OF LAND USE
(TOWN CENTRE FRAME 'H' PRECINCT)
FOR TOWN CENTRE FRAME 'H' SECTOR TWO**

Purposes for which premises may be erected or used without the consent of Council (Permitted Development) COLUMN A	Purposes for which premises may be erected or used without the consent of Council subject to conditions (Permitted Development subject to conditions) COLUMN B	Purposes for which premises may be erected or used only with the consent of Council (Permissible Development) COLUMN C	Purposes for which premises may not be erected or used (Prohibited Development) COLUMN D
Self Assessable	Code Assessable	Impact Assessable Development	
Caretaker's residence Local utilities Park	Accommodation units Amusement premises Apartments Car park Car wash (associated with an existing building or within a basement carparking area) Catering premises (ground floor only) Child care centre Commercial services Convention centre Cultural facility Educational establishment Entertainment library Family day care centre Hardware centre (associated with an existing building) Indoor recreation Licensed club Motel (where at first floor and above) Office (ground floor only on Lots 47, 48 and 51 and unrestricted on remainder) Passenger terminal (associated with an existing building) Place of worship (associated with an existing building) Restaurant (ground floor only) Retail nursery Shop <300m ² GFA (ground floor only and on Lot 51) Shopping Centre <1500m ² (in total over lots 47 and 48 and in total over lots 45, 46, 49 and 50 only and no single tenancy >300m ²) Special use Technology industry Tourist facility Vehicle hire depot (within an existing building only) Veterinary clinic	Any other Use not listed in Column A, B or D	Adult product shop Agriculture Air strip Animal husbandry Aquaculture Bulk garden supplies Camping grounds Caravan park Cattery Cemetery Concrete batching plant Contractor's depot Correctional institution Crematorium Dairy Extractive industry Fuel depot General industry Hazardous industry Heavy vehicle parking Heavy vehicle sales Host farm Junk yard Kennels Lot feeding Motor sport or shooting Piggery Poultry farm Rural industry Shopping centre >1,500m ² GLA Showground Simulated conflict Stable Stock sales yard Transport terminal Transportable home village Turf farming

APPENDIX B

PLANT LIST

**Appendix B: Indicative Plant Schedule -
Town Centre Frame "H" – Corner Memorial Drive and
Discovery Drive – Sector Two**

Botanical Name	Common Name
Trees & Palms	
Acmena smithii	Lilly Pilly
Agathis robusta	Kauri Pine
Allocasuarina littoralis	Black She Oak
Allocasuarina torulosa	Forest She Oak
Araucaria cunninghamia	Hoop Pine
Archontophoenix cunninghamia	Pickabean Palm
Backhousia citriodora	Lemon Scented Myrtle
Backhousia myrtifolia	Carrol
Banksia integrifolia	Coast Banksia
Barklya syringifolia	Crown of Gold Tree
Brachychiton acerifoliun	Flame Tree
Brachychiton rupestre	Bottle Tree
Buckinghamia celsissima	Ivory Curl Flower
Callistemon salignus	Pink Tips
Callistemon viminalis	Weeping Bottlebrush
Callitris columellaris	Bribie Island Pine
Cassia fistula	Golden Shower Tree
Cassia javanica/Cassia siamea	Cassia
Castanospermum australe	Black Bean
Casuarina cunningghiana	River She Oak
Casuarina glauca	Swamp She Oak
Cupaniopsis anacardioides	Tuckeroo
Elaeocarpus eumundii	
Eucalyptus citriodora	Lemon Scented Gum
Eucalyptus ptychocarpa	Swamp Bloodwood
Eucalyptus curtisii	Plunkett Mallee
Euodia elleryana	Pink Euodia
Ficus Hillii	Hill's Fig
Ficus macrophylla	Moreton Bay Fig
Ficus rubignosa	Port Jackson Fig
Flindersia australis	Crows Ash
Flindersia pimenteliana	Flindersia
Flindersia schottiana	Bumpy Ash
Grevillea robusta	Silky Oak
Harpullia pendula	Tulipwood
Hymenosporum flavum	Native Frangipanii
Jacaranda mimosifolia	Jacaranda
Lagerstroemia indica	Crepe Myrtle
Livistona australis	Livistona
Livistona decipiens	Weeping Cabbage Palm
Livistona nitida	Livistona
Lophostemon confertus	Brush Box
Lophostemon suaveolens	Swamp Box
Melaleuca linariifolia	Snow in Summer
Melaleuca leucadendron	Small Leaved Paperbark
Melaleuca quinquenervia	Broadleaved Paperbark
Metrosideros queenslandicus	Queensland Golden Myrtle
Oreocallis sp. nova (wickhamii)	Tree Waratah
Peltophorum pterocarpus	Yellow poinciana
Phoenix canariensis	Canary Island Palm

**Appendix B: Indicative Plant Schedule -
Town Centre Frame "H" – Corner Memorial Drive and
Discovery Drive – Sector Two**

Botanical Name	Common Name
Trees & Palms	
Podocarpus elatus	Brown Pine
Roystonea regia	Cuban Royal Palm
Syzygium australe	Scrub Cherry
Syzygium franchisee	Giant Water Gum
Syzygium jambos	Rose Apple
Syzygium leuhmanii	Small Leaved Lilly Pilly
Syzygium paniculatum	Dwarf Magenta Cherry
Tristanopsis laurina	Water Gum
Waterhousia floribunda	Weeping Myrtle
Xanthostemon chrysanthus	Golden Penda
Shrubs	
Baeckea sp. Mt Toza	Dwarf Baeckea
Baeckea virgata	Twiggy Myrtle
Baeckea virgata dwarf	Dwarf Baeckea
Banksia Birthday Candles	Dwarf Banksia
Banksia ericifolia	Heath Banksia
Banksia integrifolia	Coastal Banksia
Banksia robur	Swamp Banksia
Banksia spinulosa var collina	Hairpin Banksia
Callistemon Dawson River	Dawson River
Callistemon Little John	Little John
Callistemon Ned Kelly	Ned Kelly
Callistemon pachyphyllus	Bottlebrush
Cyathea australis	Rough Tree Fern
Gardenia Florida	Double Gardenia
Grevillea "Coconut Ice"	Coconut Ice
Grevillea "Majestic"	Majestic
Grevillea "Robyn Gordon"	Grevillea
Grevillea "Superb"	Superb
Grevillea banksii	Red Silky Oak
Grevillea Honey Gem	Honey Gem
Grevillea Ned Kelly	Ned Kelly
Hibiscus rosa sinensis	Hibiscus
Hovea acutifolia	Pointed Leaf Hovea
Leptospermum flavescens	Tantoon Tea Tree
Leptospermum petersonii	Lemon Scented Tea Tree
Leptospermum Pink Cascade	Pink Cascade
Melaleuca linariifolia Snowflake	Dwarf Tea Tree
Murraya paniculata	Orange Jessamine
Pittosporum revolutum	Brisbane Laurel
Pittosporum undulatum	Mock Orange
Syzygium Blaze	Dwarf Lilly Pilly
Syzygium Elite	Compact Lilly Pilly
Syzygium Tiny Trev	Dwarf Lilly Pilly
Tibouchina jules	Tibouchina
Westringea fruticosa	Wynyabbie Gem

**Appendix B: Indicative Plant Schedule -
Town Centre Frame "H" – Corner Memorial Drive and
Discovery Drive – Sector Two**

Botanical Name	Common Name
Groundcovers	
Agapanthus africanus	Lily of the Nile
Agapanthus orientalis	Lily of the Nile
Agapanthus Peter Pan	Dwarf Agapanthus
Anigozanthos hybrids	Kangaroo Paws
Blechnum cartilagineum	Fern
Cissus rhombifolium	Grape Ivy
Cissus Ellen Danica	Grape Ivy
Crinum pendunculatum	River Lily
Dianella revoluta	Flax Lily
Dietes bicolor	Japanese Iris
Dietes grandiflora	Japanese Iris
Evolvulus pilosus	Blue Sapphire
Gardenia radicans	Dwarf Gardenia
Grevillea Bronze Rambler	Bronze Rambler
Grevillea Royal Mantle	Prostrate Grevillea
Hardenbergia violacea	Purple Coral Pea
Hardenbergia violacea Bushy Blue	Bushy Blue
Helichrysum ramosissimum	Yellow Buttons
Hemerocallis species	Day Lily
Hibbertia dentata	Toothed Guinea Flower
Hibbertia scandens	Snake Vine
Liriope "Evergreen Giant"	Liriope
Lomandra hystrix	Creek Mat rush
Lomandra longifolia	Mat Rush
Lomandra multiflora	Long Leaved Mat Rush
Myoporum ellipticum	Creeping Boobialla
Myoporum parvifolium	Myoporum
Pittosporum Miss Muffet	Dwarf Pittosporum
Pittosporum tobira	Miss Muffet
Viola hederacea	Native Violet
Zierra Carpet Star	Carpet Star
Grasses	
Cynodon dactylon	Green Couch
Danthonia induta	Wallaby Grass
Digitaria didactyla	Blue Couch
Greenlees Park	Hybrid Couch
Poa australis	Native Poa
Vines	
Jasminum polyanthum	Jasmine
Pandorea pandorana	Wonga Wonga Vine
Pandorea jasminoides	Bower of Beauty
Trachelospermum jasminoides	Variegated Star Jasmine
Trachelospermum jasminoides	Star Jasmine

APPENDIX C

Bicycle Parking Requirements

BICYCLE PARKING REQUIREMENTS (TOWN CENTRE FRAME 'H' PRECINCT) FOR TOWN CENTRE FRAME 'H' SECTOR TWO

Land use	Employee Bicycle Parking spaces	Class	Visitor/Shopper Bicycle Parking spaces	Class
Accommodation units (above ground level)	1 per 4 habitable rooms	1	1 per 16 habitable rooms	3
Amusement premises	1 space per 4 employees	2	2 plus 1 per 50m ² GFA	3
Apartments (above ground floor)	1 per 4 habitable rooms	1	1 per 16 habitable rooms	3
Car park	1 space per 750m ² GFA	1	1 space per 50 car parking spaces	3
Car wash	1 space per 750m ² GFA	2	N/A	
Catering premises	1 space per 100m ² GFA public area	2	2 spaces	3
Commercial services	1 space per 200m ² GFA	2	1 space per 750m ² GFA over 1000m ² GFA	3
Convention centre	1 per 1500m ² GFA	2	1 space per 750m ² GFA over 1000m ² GFA	3
Cultural facility	1 space per 300m ² GFA	1 or 2	1 space per 200m ²	3
Entertainment library	1 space per 300m ² GFA	2	1 space per 200m ²	3
Hardware centre	1 space per 300m ² GFA	2	1 space per 200m ²	3
Indoor recreation	1 space per 4 employees	1 or 2	1 space per 200m ² GFA	3
Motel (accommodation generally above ground level)	1 per 40 rooms	1	N/A	N/A
Office	1 space per 200m ² GFA	2	1 space per 750m ² GFA over 1000m ² GFA	3
Restaurant	1 space per 100m ² GFA public area	1 or 2	2 spaces	3
Retail nursery	1 space per 300m ² GFA	1 or 2	1 space per 200m ²	3
Shop < 300m ² GFA	1 space per 300m ² GFA	1 or 2	1 space per 200m ²	3
Shopping centre <1,500m ² GLA	1 space per 300m ² GFA	1 or 2	1 space per 200m ²	3
Special use	N/A	N/A	N/A	N/A
Technology industry	1 space per 300m ² GFA	1 or 2	1 space per 200m ²	3
Tourist facility	1 space per 300m ² GFA	1 or 2	1 space per 200m ²	3
Vehicle Hire Depot	1 space per 750m ² GFA (excluding outdoor vehicle display area)	2	1 space per 200m ²	3
Veterinary clinic	1 space per 200m ² GFA	1 or 2	1 space per 750m ² GFA over 1000m ² GFA	3

Notes:-

- GFA – Gross floor area, as defined in the DCP;
- The provision of bicycle spaces recommended in the table may be staged initially depending on the demand for use, however space should be set aside to allow 100% provision in the event that the full demand for bicycle parking is realised.

Types of Parking Devices

Class	Security Level	Description	Main User Type
1	High	Fully enclosed individual lockers	Bike and ride commuters at railway and bus stations.
2	Medium	Located compounds fitted with Class 3 facilities. Communal access using duplicate keys or electronic swipe cards	Regular employees, students, regular bike and ride commuters.
3	Low	Facilities to which the bicycle frame and wheels can be locked	Shoppers, visitors to public offices, places of employment where there is security supervision of the parking facilities.

APPENDIX D

TOWN CENTRE FRAME SIGNAGE GUIDELINES



NORTH LAKES

NORTH LAKES TOWN CENTRE FRAME SIGNAGE GUIDELINES

1.0 OBJECTIVES

The objectives of the signage standards for North Lakes are:

- (i) To implement design standards consistent with the existing and future character of North Lakes
- (ii) To ensure that signs and advertisements complement the attractiveness, safety, legibility and amenity of the North Lakes environment, both day and night
- (iii) To support the role of signs and advertising as an important factor in the marketing of North Lakes and in identifying the commercial character in areas of the development.

2.0 DEFINITIONS

Animated Signage:

An animated sign is an advertisement with a changing display, such as flashing or chasing bulbs, or any other non-static illuminated displays.

Third Party Advertising:

A “third party” advertising sign is an advertisement for a business not conducted on the land on which the sign is located, or a commodity not available on that land, and includes an advertisement for a particular brand of product sold or distributed from the premises. However, an advertising sign which incorporates the North Lakes logo as an integral element of the signage, or a sign which includes only a generic reference to the type of product available on the land is not a “third party” advertising sign in terms of the inclusion of the North Lakes logo or the generic product reference.

On- Site Business Advertising:

An on-site business advertising sign is an advertising sign which is limited in its content to the name of a business premises and the name and services offered by the occupants of the business premises. An on-site business advertising sign may also incorporate the North Lakes logo as an integral element of the signage.

Artworks/Murals:

Artwork and murals are architectural graphics and other artworks which do not contain any implied or direct reference to a business undertaking or service or commodity available from a business undertaking. However, artworks and murals may incorporate the North Lakes logo as a supporting or an ancillary element.

3.0 SIGNAGE GUIDELINES

Except in the case of road signs, the following guidelines will be applied to all advertising signage erected in the North Lakes Town Centre Core. The following guidelines are to be read in association with the guidelines contained in Section 7.9.1 of this Sector Plan.

These guidelines are intended to apply for individual signs, but where they form part of a coordinated signage plan, they can be varied.

3.1. Scale and Location of Signs on Buildings

The scale of the sign shall be compatible with the building and building elements on which it is affixed and to which it is in proximity, as well as nearby buildings, streets and other existing signs. Consideration shall be given to the sign's relationship to the overall appearance of the development as well as surrounding development.

The number and area of signs, if specified, are intended to be maximum standards.

3.2. Principal Developer Signs

Within road reservations and on land in ownership of the Council or the principal developer, signage content is limited to the message requirements of the principal developer and traffic control. Generally content of signs within these areas will be restricted to directional information for identifying locations, buildings, services and events. Commercial business names or logos will generally not be permitted except for sponsorships on temporary event signs.

3.3. Traffic Safety

A sign must not obstruct pedestrians' views of traffic or vehicle driver's views of pedestrians, other traffic or the road ahead. A sign must not create possible confusion for drivers at critical locations such as intersections, traffic signals, or merging and weaving situations eg. red and green lit signage near traffic intersections.

3.4. Installation Fixings

No support, fixing, suspension or other systems required for the installation of a sign shall be exposed, unless designed as an integral feature of the sign. Conduits, wiring, switches etc shall be discreetly placed out of general view.

3.5. Animated Signs

Animated signs, where parts or all of the sign components move, may be acceptable in non-residential environments where no significant adverse impacts are likely to adjacent or nearby sensitive land uses.

3.6. Clutter

The visual amenity of the local area and the effectiveness of the message on the sign will be enhanced by reducing signage clutter. Proposed signs shall be assessed in the context of the number, type, size and location of existing signs on the site and surrounds.

3.7. Illumination

The luminance of an externally illuminated advertisement in the Town Centre Core (measured in candelas per square metre) is not to exceed 500 cd/m².

The luminance level of an advertisement may exceed this level where it can be shown that the increase in luminance level is unlikely to contribute to a traffic hazard or cause an inappropriate loss of amenity.

The external illumination of signs is to be carried out in such a way as to minimise the spill effects beyond the target sign. An illuminated sign must be designed to make the best possible use of the energy efficient equipment and light sources available.

At street level sign illumination is to be consistent with the general level of lighting so as to eliminate shadows and promote the safety of adjoining public areas.

The intensity of lighting and hours of illumination must not unreasonably impact on any residential properties or traffic operations.

3.8. Environmental Controls

A sign must not be nailed or similarly fixed to a tree. Every sign shall be maintained and kept in good repair.

3.9. Performance Controls

Unless otherwise approved under the coordinated signage plan, a proposed sign must meet the performance criteria outlined in the following section. The acceptable standards associated with each type of sign are provided as examples and should not be seen as precluding other solutions. However, where alternative solutions are proposed, the onus will be on the proponent to demonstrate that the relevant performance criteria are met.

SIGNS PERFORMANCE CRITERIA



Signs shall:

- (i) not create a hazard to traffic or pedestrians**
- (ii) be of character and design standard consistent with the objectives and controls for this sector plan**
- (iii) complement the streetscape and amenity of the locality by virtue of their size, location, illumination, utilisation of complementary shapes, forms, colours, durable quality materials and design concepts**
- (iv) if affixed to a building, complement the architectural style of the building by virtue of their size, location, illumination, utilisation of complementary shapes, forms, colours, durable quality materials and design concepts; and**
- (v) not unnecessarily repeat or duplicate similar signs.**

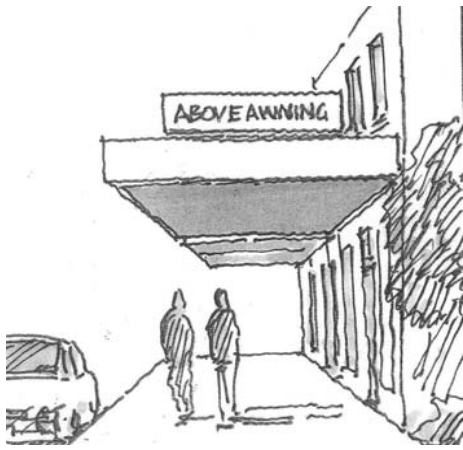

4.0 TYPES OF SIGNS

The following schedule sets out maximum criteria for various types of signs. Such signs may be permitted subject to the overall performance standards being met.

- (i) Above Awning Sign
- (ii) Awning / Fascia Sign
- (iii) Billboard Sign
- (iv) Blind Sign
- (v) Business Plate
- (vi) Canopy Sign
- (vii) Created Awning Sign
- (viii) Flag Pole Sign
- (ix) Footway Sign
- (x) Ground Sign
- (xi) Hamper Sign
- (xii) Highrise Building Sign
- (xiii) Lantern Sign
- (xiv) Pole Sign
- (xv) Projecting Flag Sign
- (xvi) Projecting Sign
- (xvii) Stallboard Sign
- (xviii) Under Awning Sign
- (xix) Vertical Banner Building Sign
- (xx) Vertical Banner Freestanding Sign
- (xxi) Wall Sign
- (xxii) Window Sign

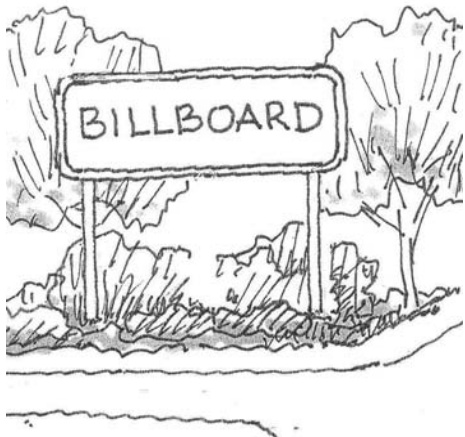
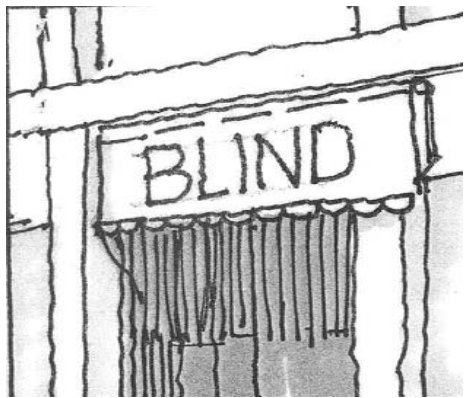

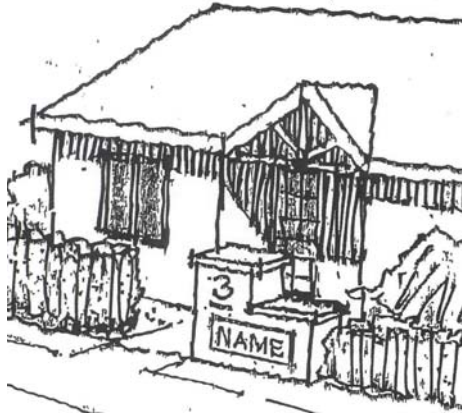
TYPE OF SIGN	EXAMPLE OF TYPE OF SIGN	ACCEPTABLE STANDARD FOR SPECIFIC SIGN STYLE	
<p>ABOVE AWNING SIGN An Above Awning Sign is an advertisement above an awning, verandah roof or the like.</p>		<p>Maximum size</p> <p>Maximum height above awning</p> <p>Extent</p> <p>Other requirements</p>	<p>Length - 2.7 metres</p> <p>Height - 0.6 metres</p> <p>Width - 0.3 metres</p> <p>1.0 metre</p> <p>Not to project beyond the edges of the awning</p> <p>No unsightly supports or rear view of sign.</p> <p>Any unsightly supports required for structural reasons are to be set back behind edges of sign</p>
<p>AWNING/FASCIA SIGN An Awning/Fascia Sign is an advertisement painted or otherwise affixed to the fascia of a building, an awning, verandah or return end of an awning.</p>		<p>Maximum extent</p> <p>Maximum height</p> <p>Maximum thickness</p>	<p>Not projecting above or below the fascia</p> <p>0.6 metre</p> <p>0.1 metre out from fascia</p>

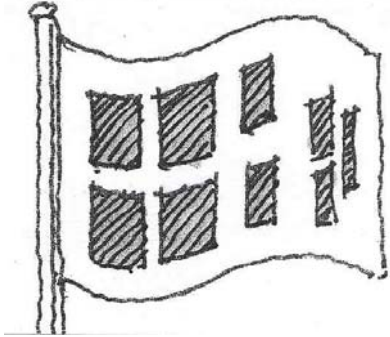

TYPE OF SIGN	EXAMPLE OF TYPE OF SIGN	ACCEPTABLE STANDARD FOR SPECIFIC SIGN STYLE	
<p>BILLBOARD SIGN A Billboard Sign is a freestanding display surface, the width of which is greater than the height and which may be positioned on the ground or mounted on one or more vertical supports.</p>		<p>Maximum area</p> <p>Maximum height above ground to top of sign</p> <p>Setting</p> <p>Minimum setback from side boundary</p> <p>Front setback</p> <p>Maximum</p>	<p>20 square metres per side for a maximum of 2 sides</p> <p>6.5 metres or the height of a building in close proximity whichever is the lesser</p> <p>As a free standing structure within a landscaped environment and so as not to expose an unsightly back view of the sign to a road or other public places</p> <p>3.0 metres</p> <p>Not to project beyond front property alignment</p> <p>Generally no billboard shall be erected on a site along which are located Pylon or Large Pylon signs unless the frontage exceeds 100m in which case a separation of 60m must be achieved.</p>
<p>BLIND SIGN A Blind Sign is an advertisement painted on or otherwise affixed to solid or flexible material suspended from the edge of an awning, verandah or wall.</p>		<p>Minimum clearance between the lower most point of the sign and the footway</p> <p>Maximum number</p>	<p>2.4 metres</p> <p>1 per tenancy frontage</p>

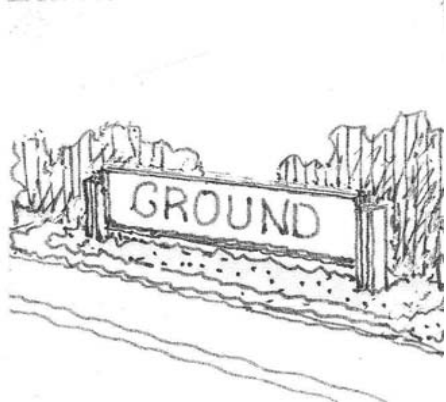
TYPE OF SIGN	EXAMPLE OF TYPE OF SIGN	ACCEPTABLE STANDARD FOR SPECIFIC SIGN STYLE	
<p>BUSINESS PLATE A Business Plate is a small advertisement identifying the name and/or trade, business or calling of the occupant or business premises. A Business Plate may be painted or affixed to a wall.</p>		<p>Maximum surface area of sign residence in a residential area Maximum surface area per business occupant of premises in commercial and mixed use areas</p>	<p>0.3 square metres 0.3 square metres</p>
<p>CANOPY SIGN A Canopy Sign is an advertisement, painted or otherwise affixed, to a canopy, whether the canopy is constructed from flexible or solid material.</p>		<p>Minimum clearance between the lower most part of the sign and the footway Maximum number</p>	<p>2.4 metres 1 per tenancy frontage</p>



TYPE OF SIGN	EXAMPLE OF TYPE OF SIGN	ACCEPTABLE STANDARD FOR SPECIFIC SIGN STYLE	
<p>CREATED AWNING LINE SIGN A Created Awning Line Sign is an advertisement attached to and extending beyond a fascia of an awning or the like.</p>		<p>Extent</p> <p>Maximum area</p> <p>Minimum clearance</p>	<p>Not more than 0.6 metre above the fascia to which it is attached</p> <p>The created area is not to exceed 25% of the fascia</p> <p>2.4 metres to the footpath pavement</p>
<p>FLAG POLE SIGN A Flag Pole Sign is a fabric sign hung from a pole.</p>		<p>Maximum surface area</p> <p>Maximum height above ground</p>	<p>3.0 square metres</p> <p>6.5 metres if planted in the ground</p>

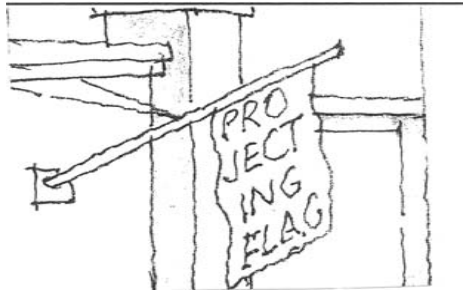
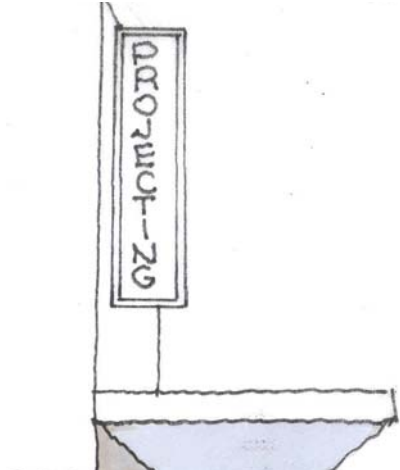

TYPE OF SIGN	EXAMPLE OF TYPE OF SIGN	ACCEPTABLE STANDARD FOR SPECIFIC SIGN STYLE	
<p>FOOTWAY SIGN A Footway Sign is a portable, freestanding advertisement, normally supported by an 'A' or inverted 'T' frame, and typically displayed on a footway.</p>		<p>Maximum size</p> <p>Maximum number</p> <p>Location</p> <p>Other requirements</p>	<p>Height - 1.0 metre Width - 0.6 metre Depth - 0.6 metre</p> <p>1 per tenancy</p> <p>A Footway Sign on a footway is to be positioned near the kerb (but not closer than 0.25 metre) so as to leave clear passage for pedestrians along the footway, particularly the visually disadvantaged who rely on clear passage along the frontage of shops.</p> <p>No footway sign is to be positioned so as to obstruct, clutter or detract from street landscaping, furniture or artwork</p> <p>A Footway Sign not to be located on a public road.</p> <p>A Footway Sign is not to have moving, rotating or animated parts, such as a spinner sign. A Footway Sign is to be displayed only during trading hours and is not to be used for the display of merchandise</p>
<p>GROUND SIGN A Ground Sign is a monolithic sign which, in effect, sits on or rises out of the ground.</p>		<p>Setting</p> <p>Maximum height</p> <p>Maximum surface area</p> <p>Maximum setback from side boundary</p> <p>Maximum number</p>	<p>Erected within a landscaped environment.</p> <p>Not erected to expose an unsightly back view of the sign.</p> <p>When in a residential area, only permitted where used in a name of a multi-unit development site</p> <p>1.8 metres</p> <p>10 square metres</p> <p>3 metres</p> <p>One per frontage for frontages up to 100 metres</p> <p>For frontages over 100 metres, spacing of signs to be no less than 60 metres</p>

TYPE OF SIGN	EXAMPLE OF TYPE OF SIGN	ACCEPTABLE STANDARD FOR SPECIFIC SIGN STYLE	
<p>HAMPER SIGN A Hamper Sign is an advertisement, painted or otherwise affixed, between a door head and an awning, or their equivalent levels.</p>		<p>Maximum thickness Maximum Extent</p>	<p>0.3 metre from the face of the wall The size and form are to be compatible with the building on which they are located.</p>
<p>HIGH RISE BUILDING SIGN A High Rise Building Sign is an advertisement naming or identifying a high rise building by the use of a logo or the like.</p>		<p>Maximum extent Maximum number Other requirements</p>	<p>Contained within the actual or created outline of a building or appears as if it was part of the original building if part of a structure creating a changed building outline One per building frontage A High Rise Building Sign is not to contain third party advertising</p>

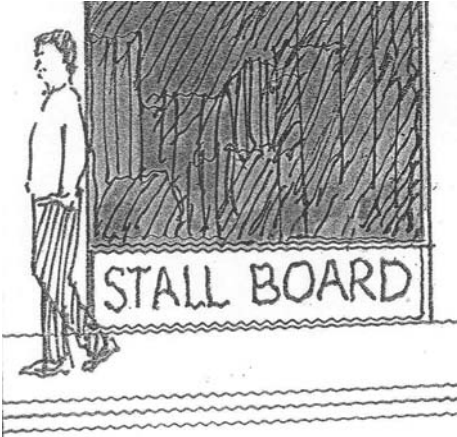
TYPE OF SIGN	EXAMPLE OF TYPE OF SIGN	ACCEPTABLE STANDARD FOR SPECIFIC SIGN STYLE	
<p>LANTERN SIGN A Lantern Sign is a translucent lighting fixture displaying the name and/or trade, business or calling of the occupant.</p>		<p>Maximum number for a Home Occupation or Business</p> <p>Maximum edge dimension of lantern</p> <p>Maximum height</p> <p>Maximum illumination</p>	<p>One</p> <p>0.5 metre (ie to fit into a Cube of 0.5 x 0.5 x 0.5 metres)</p> <p>2 metres</p> <p>Not greater than a standard 100 watt incandescent bulb</p>
<p>POLE SIGN A Pole Sign is a freestanding sign mounted on one or more vertical supports which has a smaller surface area and a lower height than a Pylon/Column sign.</p>		<p>Maximum number</p> <p>Aspect</p> <p>Maximum surface area</p> <p>Maximum height above ground</p> <p>Minimum setback from side boundary</p> <p>Setting</p>	<p>One two-sided pole sign per allotment street frontage</p> <p>Not erected to expose an unsightly back view of the sign</p> <p>2.4m² per side for a maximum of two sides.</p> <p>4.5 metres</p> <p>3 metres</p> <p>Erected within a landscaped environment</p>

TYPE OF SIGN	EXAMPLE OF TYPE OF SIGN	ACCEPTABLE STANDARD FOR SPECIFIC SIGN STYLE	
<p>PROJECTING FLAG SIGN A Projecting Flag Sign is a non-illuminated, wall-mounted corporate flag.</p>		<p>Maximum size Maximum number Minimum spacing Minimum clearance</p>	<p>0.3 square metre per face 4 per site 2 metres 2.4 metres to the footpath pavement.</p>
<p>PROJECTING SIGN A Projecting Sign is a double-faced sign projecting at right angles to a wall and fixed to the wall. A Projecting Sign is not an Under Awning Sign.</p>		<p>Minimum clearance between the lowermost point of the sign and the footway Maximum number Orientation Extent Maximum size</p>	<p>2.4 metres One per building frontage Vertical Not projected above the height of the wall to which it is attached Height - 3.0 metres Width - 0.75 metre</p>

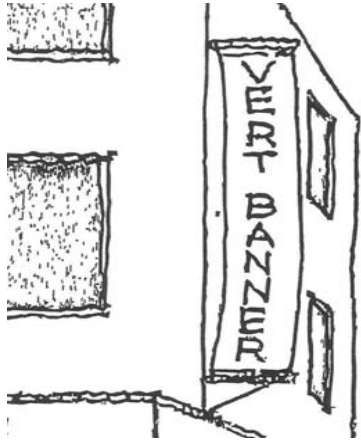
TYPE OF SIGN	EXAMPLE OF TYPE OF SIGN	ACCEPTABLE STANDARD FOR SPECIFIC SIGN STYLE	
<p>STALLBOARD SIGN A Stallboard Sign is an advertisement, painted or otherwise affixed, at the base of a shopfront, normally below a shop window</p>		<p>Fixing</p> <p>Maximum Extent</p>	<p>Fitted flush</p> <p>The size and form are to be compatible with the building on which they are located.</p>
<p>UNDER AWNING SIGN An Under Awning Sign is an advertisement suspended under an awning or verandah.</p>		<p>Orientation</p> <p>Minimum clearance between the lowermost point of the sign and footway</p> <p>Extent</p> <p>Location</p> <p>Minimum distance between under awning signs</p> <p>Maximum dimensions</p> <p>Minimum setback from side boundary</p>	<p>At right angles to the building frontage</p> <p>2.4 metres</p> <p>Not to project beyond the awning or verandah</p> <p>Central to each shop or tenancy or shopping arcade entrance</p> <p>3.0 metres</p> <p>Length - 2.7 metres or not greater than 75% of the width of the awning or verandah which ever is lesser</p> <p>Height - 0.6 metres</p> <p>Width - 0.3 metres</p> <p>1.5 metres</p>

TYPE OF SIGN	EXAMPLE OF TYPE OF SIGN	ACCEPTABLE STANDARD FOR SPECIFIC SIGN STYLE	
<p>VERTICAL BANNER BUILDING SIGN A Vertical Banner Building Sign is an advertisement of non-rigid material normally fixed at the top and bottom to brackets projecting from a building.</p>		<p>Maximum height</p> <p>Maximum width</p> <p>Minimum clearance between lowermost point of the sign and the footway</p> <p>Maximum area</p> <p>Minimum spacing between signs</p> <p>Minimum setback from side or rear boundary</p>	<p>Not to project above the height of the adjacent part of the building to which it is fixed and not to exceed 5 metres above ground level</p> <p>0.75 metre</p> <p>2.4 metres</p> <p>2.4 square metres</p> <p>6.0 metres</p> <p>3.0 metres</p>
<p>VERTICAL BANNER FREESTANDING SIGN A Vertical Banner Freestanding Sign is an advertisement of non-rigid material normally supported at two or more locations from brackets extending from a freestanding pole.</p>		<p>Maximum height (above ground level to top most support)</p> <p>Maximum width</p> <p>Minimum clearance between lowermost point of the sign and the footway</p> <p>Minimum spacing between signs</p> <p>Minimum setback from side boundary</p> <p>Maximum surface area</p>	<p>5.0 metres</p> <p>0.75 metre</p> <p>2.4 metres</p> <p>6.0 metres</p> <p>3.0 metres</p> <p>2.4 square metres</p>

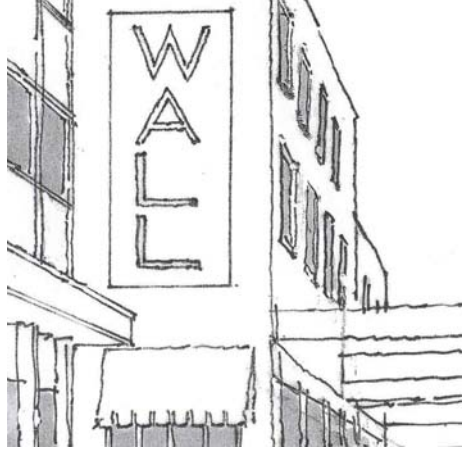
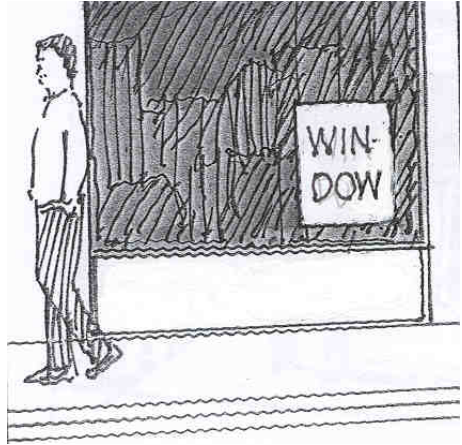
TYPE OF SIGN	EXAMPLE OF TYPE OF SIGN	ACCEPTABLE STANDARD FOR SPECIFIC SIGN STYLE	
<p>WALL SIGN A Wall Sign is an advertisement, painted or otherwise affixed, flat to a wall.</p>		<p>Maximum thickness (or projection from wall) Maximum number Maximum surface area Location</p>	<p>0.3 metre One per tenancy 20% of wall space or 6 m², whichever is the lesser Ground floor level and first floor level and not to project beyond the edge of the wall.</p>
<p>WINDOW SIGN A Window Sign is an advertisement, painted or otherwise affixed, to the glass of a display window.</p>		<p>Maximum surface area of sign</p>	<p>25% of the area of the glass panel or panels on which it is displayed</p>

APPENDIX E

PROPOSED METES AND BOUNDS DESCRIPTION OF THE SECTOR

APPENDIX F

FENCING REQUIREMENTS